

PROCESS INTEGRATION

Part 1: Heat Integration

Chapter 1: Data Extraction

by

Anwaruddin Hisyam
Faculty of Chemical and Natural Resources
Engineering
ahisyam@ump.edu.my



Chapter Description

- Aims
 - To simplify a complex process flow in order to have stream data
- Expected Outcomes
 - Students are able to extract stream data from existing process flow



In this lecture we will learn how to
simplify a complex process diagram



Let's look at an existing process below (Smith, 2005)

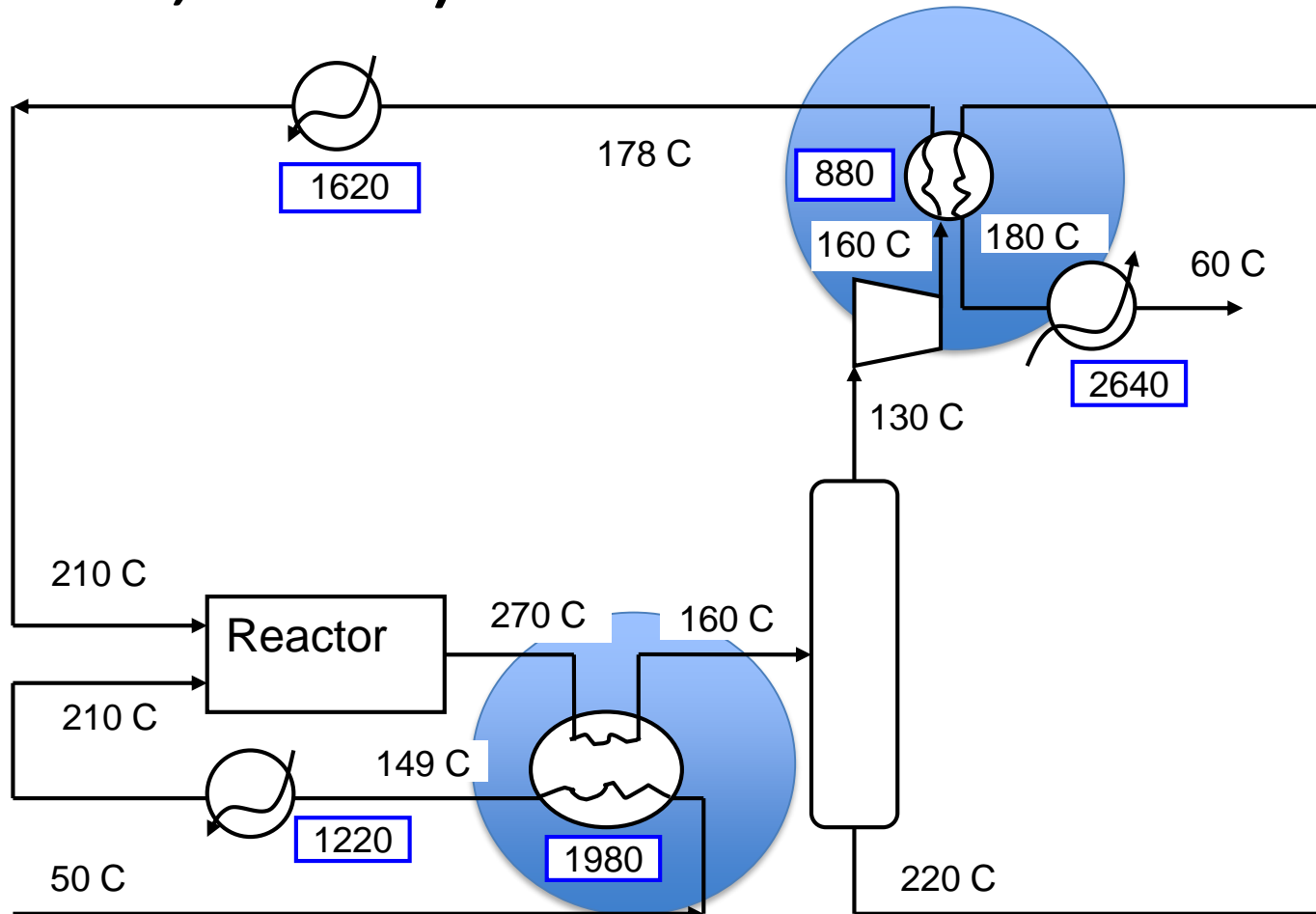

Based on the base case

- Number of heat exchangers =
- Total cooling duty =
- Total heating duty =
- Existing energy recovered =



Simplify the process for data extraction

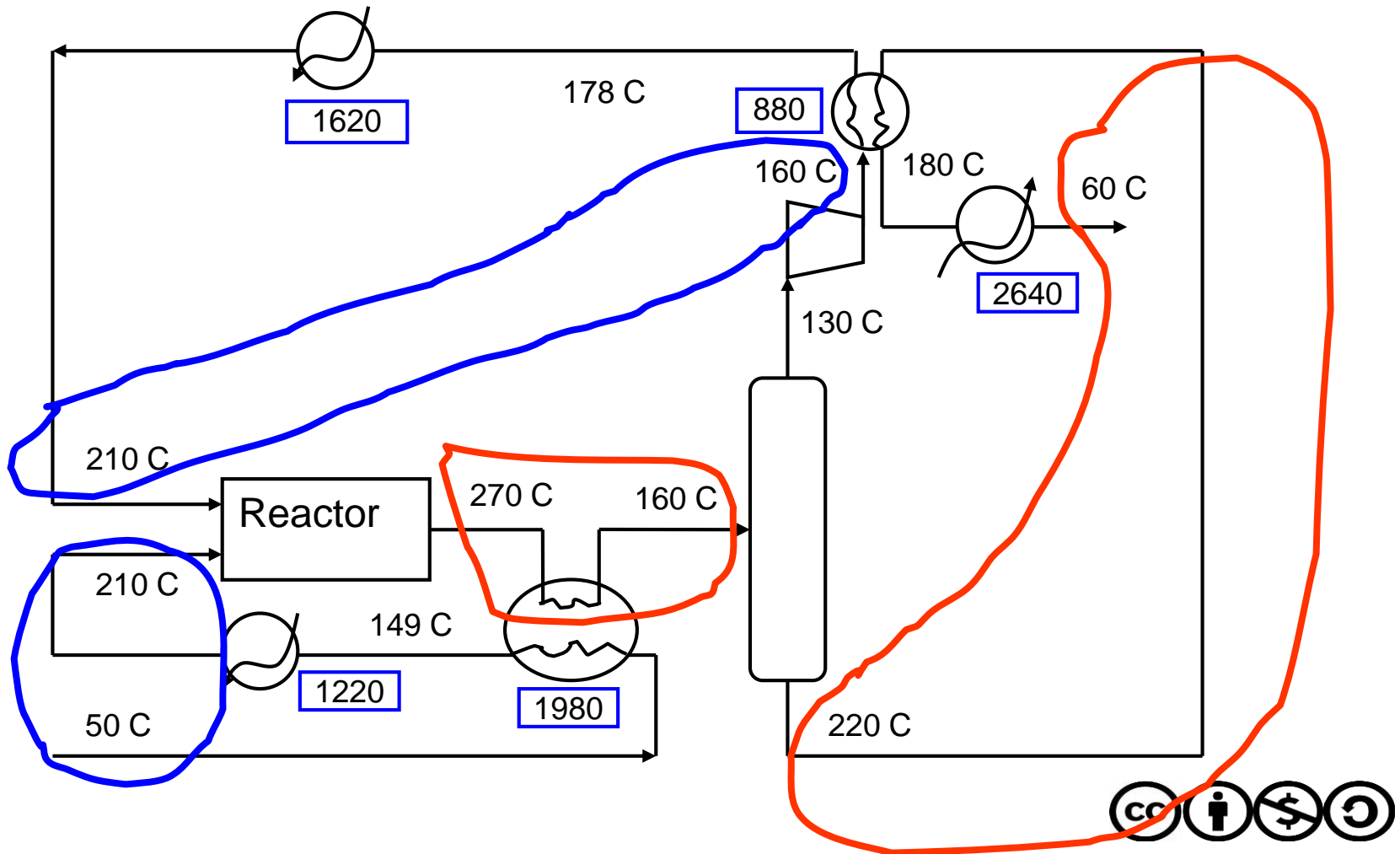

The process becomes

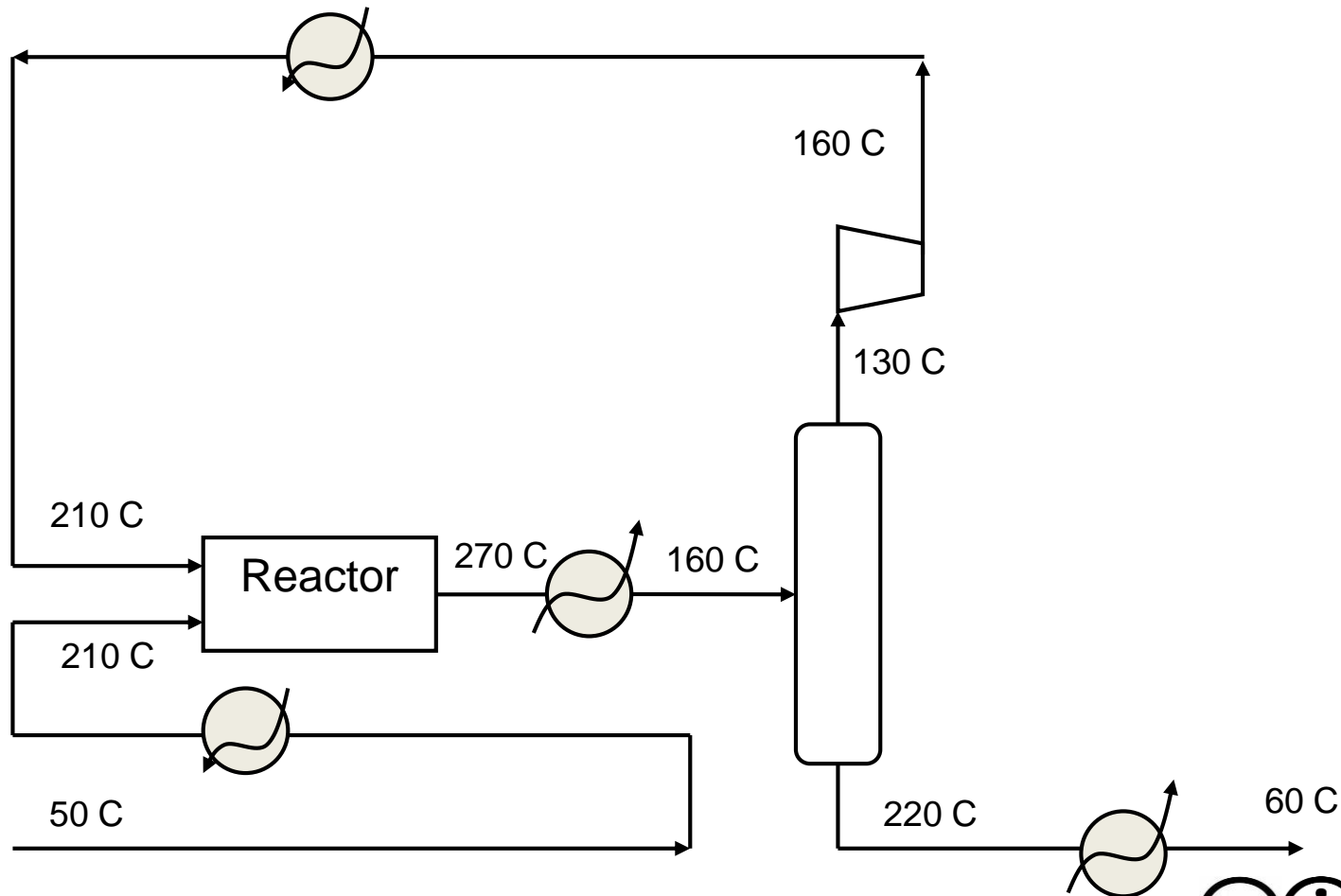
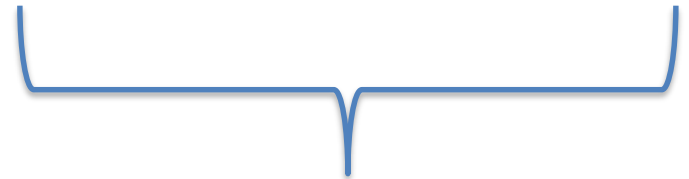

Table of data extraction

Stream	T in	T out	ΔH (Heat duty)	CP
Stream 1 (Hot)	50	210		
Stream 2 (Hot)	160	210		
Stream 3 (Cold)	220	60		
Stream 4 (Cold)	270	160		



$$Q = CP * \Delta T$$



Thank you

