

Theory of Operation...Inductive Proximity Sensors

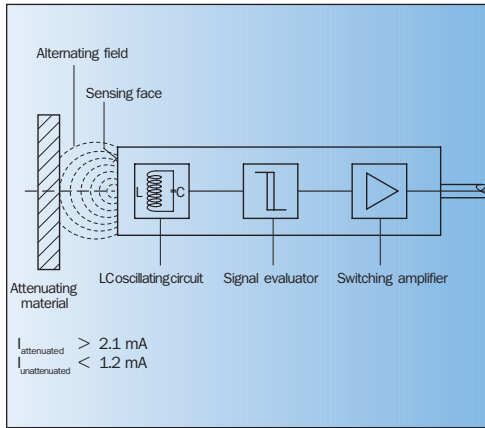

Fig. 1 Inductive proximity sensor makeup

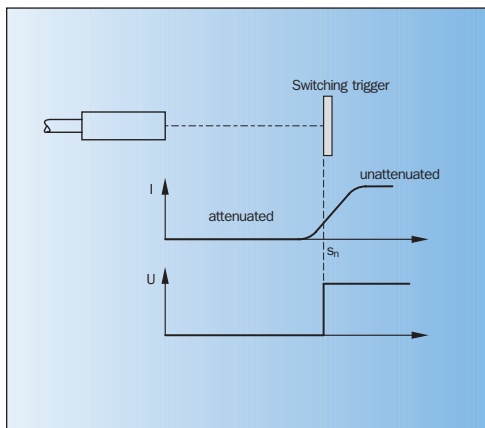

Fig. 2 Attenuated vs. unattenuated materials

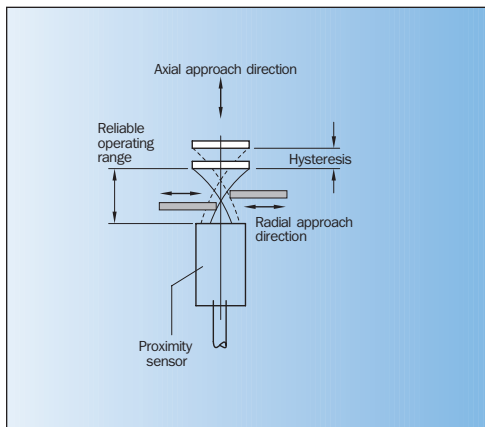

Fig. 3 Response curve for inductive sensors

About Inductive Sensors

Inductive sensors play an especially important role owing to their non-contact mode of operation, their robust industry-compatible construction and the resulting high degree of reliability as well as for economic reasons. Their non-contact mode of operation means that no actuation forces are required and direct contact with the object is avoided. The completely electronic design (no moving parts or contacts) functions without wear. The electronics are encapsulated and provide a high degree of protection against vibration and shock stress as well as dirt, dust and humidity, and as a result, the majority of these sensors can also be used in extreme conditions.

About Inductive Proximity Sensors

An inductive proximity sensor comprises an LC oscillating circuit, a signal evaluator and a switching amplifier. (See Fig. 1)

The coil of this oscillating circuit generates a high-frequency electromagnetic alternating field. This field is emitted at the sensing face of the sensor.

If attenuating material nears the sensing face, eddy currents are

generated in the case of non-ferrous metals. In the case of ferromagnetic metals, hysteresis and eddy current loss also occurs. These losses draw energy from the oscillating circuit and reduce oscillation. The signal evaluator detects this reduction and converts it into a switching signal. (See Fig. 2)

The terms "attenuated" and "unattenuated" are used to describe the two switching states of the inductive proximity sensors.

Response curve for inductive proximity sensors

The specified sensing ranges are determined in the case of axial approach along the reference axis of the sensor. (See Fig. 3)

Radial approach results in a reduction of the sensing range. The edge of the switching trigger has only a small surface area. As a result, less eddy-current losses occur. The sensor therefore only reacts if the switching trigger laterally enters the alternating field relatively close to the sensing face. In the case of axial approach, the full surface of the switching trigger is exposed to the scattered electromagnetic field. Axial alignment therefore provides the maximum sensing range.

Inductive Proximity Sensors...Type Code

Character	1	2	3	4	5	6	7	8	9	10	11	12	13	14	Character
	I	M	1	2	-	O	2	B	P	S	-	Z	U	O	
1 Sensor technology															
I Inductive															
2 Design															
H Barrel															
M Cylinder with thread															
Q Cuboid															
3/4 Housing shape															
03															
04															
05															
06															
08															
10															
12 Diameter															
18 or															
20 edge length of															
30 sensing face															
34															
40															
80															
6/7/8 Sensing range/ installation															
B Flush															
N Non-flush															
02B 2 mm; flush															
04N 4 mm; non-flush															
1B5 1.5 mm; flush															
2N5 2.5 mm; non-flush															
other codes															
K Short body housing															
Connection															
W Cable, PVC															
U Cable, PUR-PVC															
P Cable with connector, M8x1															
T Connector, M8x1															
C Connector, M12x1															
K Terminals															
Housing material															
Z Ms, nickel-plated															
V Stainless steel															
K Plastic															
Output															
S NO															
O NC															
P Programmable/complementary															
N NAMUR															
Interface															
P DC (3/4-wire) PNP															
N DC (3/4-wire) NPN															
C DC (4-wire) PNP or NPN															
D DC (2-wire)															
A AC 2-wire															
U AC/DC 2-wire															
- NAMUR															

Inductive Proximity Sensors

Sensors	Page	Sensors	Page
IM 04 mini	714	IH 06 short	786
IM 05 mini	716	IH 06 adv.	788
IM 08 std.	718	IH 06 adv. sh.	790
IM 08 short	720	IH 20 univ.	792
IM 08 adv.	722	IH 34 univ.	794
IM 08 adv. sh.	724	IQ 05 mini	796
IM 08 triple	726	IQ 08 std.	798
IM 08 NAMUR	728	IQ 10 std.	800
IM 12 std.	730	IQ 12 std.	802
IM 12 short	732	IQ 40 short	804
IM 12 2-wire	734	IQ 40 std.	806
IM 12 adv.	736	IQ 40 univ.	808
IM 12 adv. sh.	738	IQ 80 std.	810
IM 12 triple	740	IQ 80 univ.	812
IM 12 harsh	742		
IM 12 quad	744		
IM 12 univ.	746		
IM 12 NAMUR	748		
IM 18 std.	750		
IM 18 short	752		
IM 18 2-wire	754		
IM 18 adv.	756		
IM 18 triple	758		
IM 18 harsh	760		
IM 18 quad	762		
IM 18 univ.	764		
IM 18 NAMUR	766		
IM 30 std.	768		
IM 30 short	770		
IM 3- 2-wire	772		
IM 30 adv.	774		
IM 30 triple	776		
IM 30 univ.	778		
IM 30 NAMUR	780		
IH 03 mini	782		
IH 04 mini	784		

Inductive Proximity Sensors

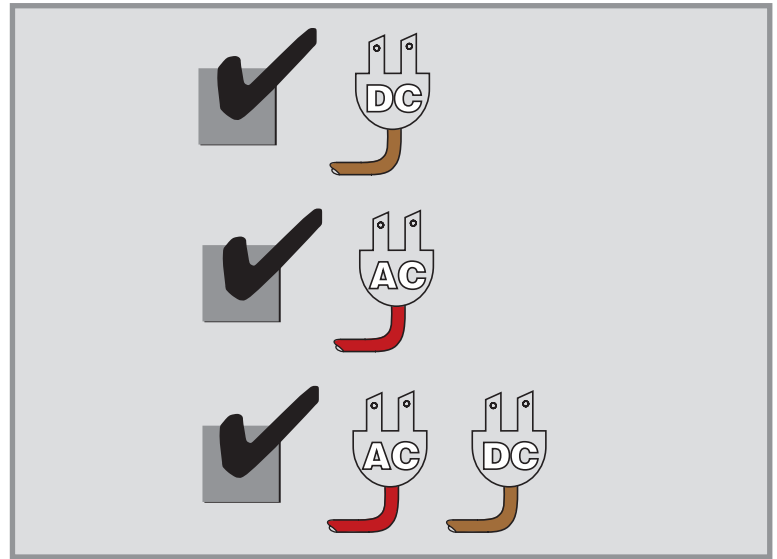

SICK



IM 04 Miniature

Inductive Proximity Sensors



Highlights

- Shielded
- PNP or NPN output
- Normally open/normally closed function
- High switching frequency
- Short circuit protection (pulsed)
- Robust brass housing, nickel-plated with fine thread M4 x 0.5 mm
- Cable
- Enclosure rating IP 67
- LED status indicator

IM 04 Miniature



Dimensional Drawing

dimensions in inches (mm)

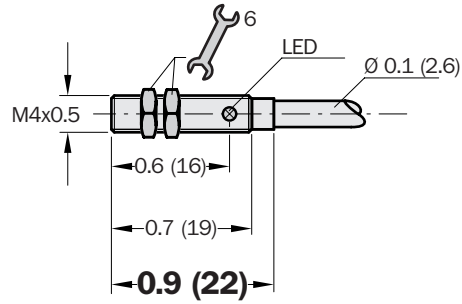

Electrical and Mechanical Data

Operating voltage U_b	10...30 V DC
Ripple U_{pp}	$\leq 20\%$ of U_b
Voltage drop U_b	≤ 0.6 V max. at $I_a = 50$ mA
Power consumption (without load)	10 mA
Continuous current I_a	≤ 100 mA
Time delay before availability t_v	≤ 10 ms
Hysteresis H typ.	10% of s_r
Repeatability R (U_b and T_a constant)	$\leq 2\%$
Temperature drift	$\pm 10\%$ of s_r
EMC	to EN 60 947-5-2
Short circuit protection (pulsed)	Yes
Reverse polarity protection	Yes
Power-up pulse suppression	Yes
Enclosure rating to DIN 40050	IP 67
Shock and vibration stress	30 g, 11 ms, 10 to 55 Hz, 1 mm
Ambient temperature T_a	-13...158°F (-25...70°C)
Housing material	Brass, nickel-plated, plastic
Tightening torque	0.8 Nm
Connection cable	PUR, 3 x 0.055 mm ²

Selection Table

Sensing range S_n in (mm)	Installation in metal	Switching output	Output function	Switching frequency f in Hz	Connection type	Type	Part no.
0.02 (0.6)		PNP		2000	Cable 2 m	IM04-0B6PS-ZU1	6 020 145
0.02 (0.6)		NPN		2000	Cable 2 m	IM04-0B6NS-ZU1	6 020 146
0.02 (0.6)		PNP		2000	Cable 2 m	IM04-0B6PO-ZU1	6 020 147
0.02 (0.6)		PNP		2000	Cable 5 m	IM04-0B6PS-ZU5	6 020 610

Connection Diagram

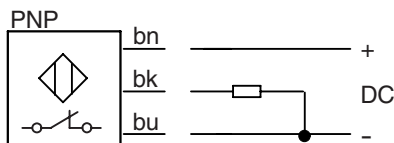
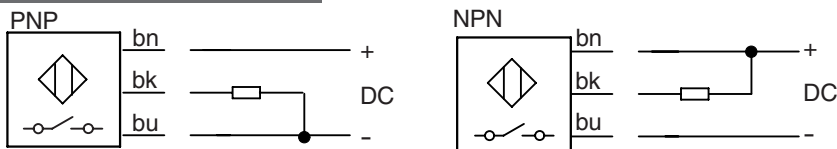

Wire color	Assignment
bn brown	+ V DC
bk black	NO/NC
bu blue	- V DC

IM 05 Miniature

Inductive Proximity Sensors



Highlights

- Shielded
- PNP or NPN output
- Normally open/normally closed function
- High switching frequency
- Short circuit protection (pulsed)
- Robust brass housing, nickel-plated with fine thread M5 x 0.5 mm
- Cable or connector
- Enclosure rating IP 67
- LED status indicator

IM 05 Miniature



Dimensional Drawing

dimensions in inches (mm)

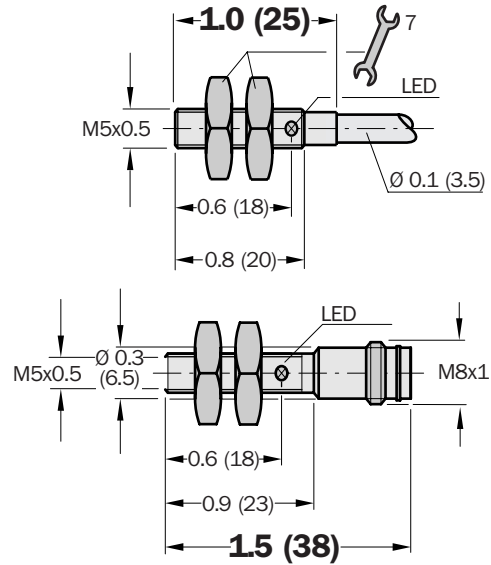

Accessories	page
Cables and connectors	908

Electrical and Mechanical Data

Operating voltage U_b	10...30 V DC
Ripple U_{pp}	$\leq 20\%$ of U_b
Voltage drop U_b	≤ 2.0 V max. at $I_a = 200$ mA
Power consumption (without load)	10 mA
Continuous current I_a	≤ 200 mA
Time delay before availability t_v	≤ 10 ms
Hysteresis H	10% of s_r
Repeatability R (U_b and T_a constant)	$\leq 1.5\%$
Temperature drift	$\pm 10\%$ of s_r
EMC	to EN 60 947-5-2
Short circuit protection (pulsed)	Yes
Reverse polarity protection	Yes
Power-up pulse suppression	Yes
Enclosure rating to DIN 40050	IP 67
Shock and vibration stress	30 g, 11 ms, 10 to 55 Hz, 1 mm
Ambient temperature T_a	-13...158°F (-25...70°C)
Housing material	Brass, nickel-plated, plastic
Tightening torque	1.5 Nm
Connection cable	PVC, 3 x 0.14 mm ²

Selection Table

Sensing range S_n in (mm)	Installation in metal	Switching output	Output function	Switching frequency f in Hz	Connection type	Type	Part no.
0.02 (0.8)		PNP		5000	Cable 2 m	IM05-OB8PS-ZW1	6 011 591
0.02 (0.8)		NPN		5000	Cable 2 m	IM05-OB8NS-ZW1	6 020 155
0.02 (0.8)		NPN		5000	Cable 2 m	IM05-OB8NO-ZW1	6 020 157
0.02 (0.8)		PNP		5000	Connector M8 x 1 mm	IM05-OB8PS-ZT1	6 020 110
0.02 (0.8)		NPN		5000	Connector M8 x 1 mm	IM05-OB8NS-ZT1	6 020 158
0.02 (0.8)		PNP		5000	Connector M8 x 1 mm	IM05-OB8PO-ZT1	6 020 159

Connection Diagram

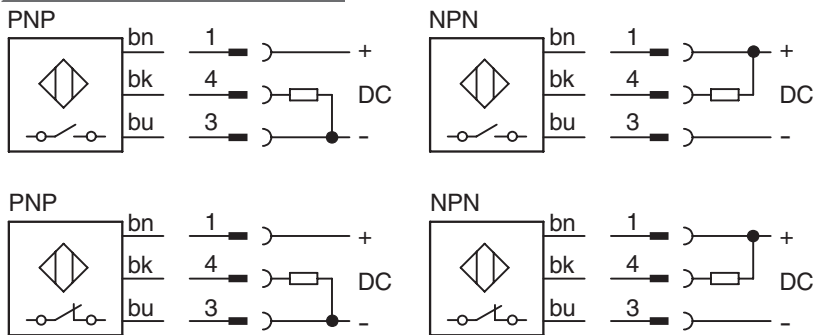

Wire color	Contact	Assignment
bn	brown	1 + V DC
bk	black	4 NO/NC
bu	blue	3 - V DC

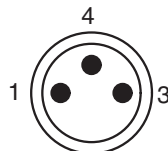

IM 08 Standard

Inductive Proximity Sensors



Highlights

- Shielded or unshielded
- PNP or NPN output
- Normally open/normally closed function
- High switching frequency
- LED status indicator
- Short circuit protection (pulsed)
- Robust brass housing, nickel-plated with fine thread M8 x 1 mm
- Cable or connector
- Enclosure rating IP 67

IM 08 Standard



Dimensional Drawing

dimensions in inches (mm)

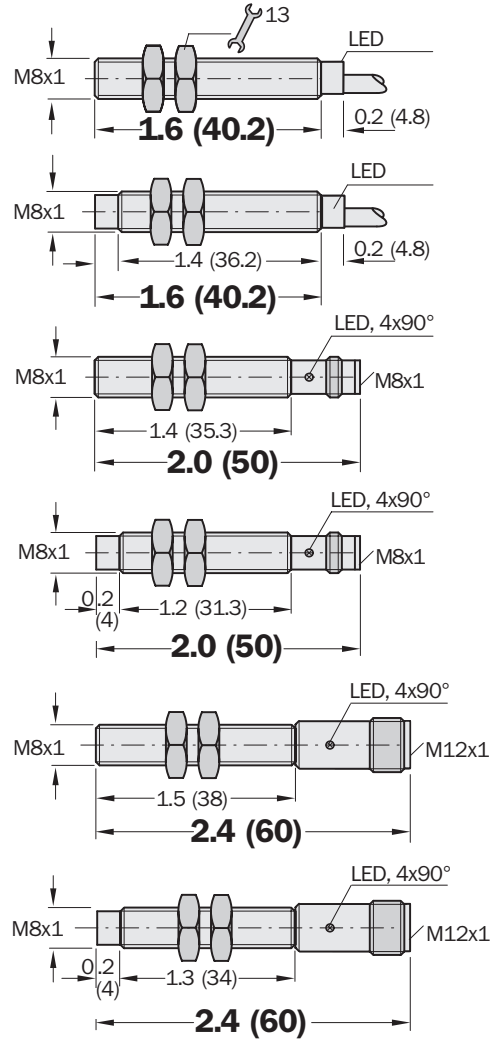

Accessories	page
Cables and connectors	908, 909

Electrical and Mechanical Data

Operating voltage U_b	10...30 V DC
Ripple U_{pp}	$\leq 10\%$
Voltage drop U_b	≤ 1.2 V at I_a max.
Power consumption (without load)	≤ 20 mA
Continuous current I_a	≤ 200 mA
Time delay before availability t_v	≤ 100 ms
Hysteresis H	2% - 10% of s_r
Repeatability R (U_b and T_a constant)	$\leq 2\%$ of s_r
Temperature drift	$\pm 10\%$ of s_r
EMC	to EN 60 947-5-2
Short circuit protection (pulsed)	Yes
Reverse polarity protection	Yes
Power-up pulse suppression	Yes
Enclosure rating to DIN 40050	IP 67
Shock and vibration stress	30 g, 11 ms, 10 to 55 Hz, 1 mm
Ambient temperature T_a	-13...158°F (-25...70°C)
Housing material	Brass, nickel-plated, plastic
Tightening torque	4 Nm
Connection cable	PVC, 3 x 0.14 mm ²

Selection Table

Sensing range S_n in (mm)	Installation in metal	Switching output	Output function	Switching frequency f in Hz	Connection type	Type	Part no.
0.06 (1.5)		PNP		3000	Cable 2 m	IM08-01B5PS-ZW1	6 020 215
0.06 (1.5)		NPN		3000	Cable 2 m	IM08-01B5NS-ZW1	6 020 216
0.06 (1.5)		PNP		3000	Cable 2 m	IM08-01B5PO-ZW1	6 020 217
0.06 (1.5)		NPN		3000	Cable 2 m	IM08-01B5NO-ZW1	6 020 218
0.06 (1.5)		PNP		3000	Connector M8 x 1 mm	IM08-01B5PS-ZT1	6 020 219
0.06 (1.5)		NPN		3000	Connector M8 x 1 mm	IM08-01B5NS-ZT1	6 020 220
0.06 (1.5)		PNP		3000	Connector M8 x 1 mm	IM08-01B5PO-ZT1	6 020 221
0.06 (1.5)		PNP		3000	Connector M12 x 1 mm	IM08-01B5PS-ZC1	6 020 223
0.06 (1.5)		NPN		3000	Connector M12 x 1 mm	IM08-01B5NS-ZC1	6 020 224
0.1 (2.5)		PNP		2500	Cable 2 m	IM08-02N5PS-ZW1	6 020 227
0.1 (2.5)		NPN		2500	Cable 2 m	IM08-02N5NS-ZW1	6 020 228
0.1 (2.5)		PNP		2500	Connector M8 x 1 mm	IM08-02N5PS-ZT1	6 020 231
0.1 (2.5)		NPN		2500	Connector M8 x 1 mm	IM08-02N5NS-ZT1	6 020 232
0.1 (2.5)		PNP		2500	Connector M12 x 1 mm	IM08-02N5PS-ZC1	6 020 235
0.1 (2.5)		NPN		2500	Connector M12 x 1 mm	IM08-02N5NS-ZC1	6 020 236

Connection Diagram

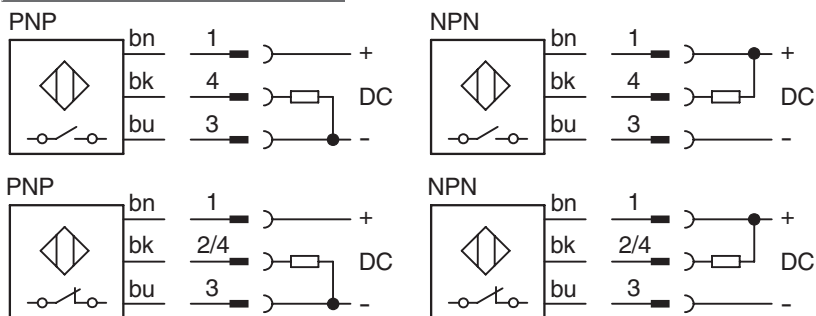

Wire color	Contact M8	Contact M12	Assignment
bn brown	1	1	+ V DC
bk black	4	2/4	NO/NC
bu blue	3	3	- V DC

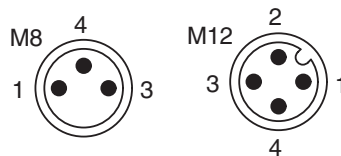

IM 08 Short

Inductive Proximity Sensors



Highlights

- Shielded
- PNP or NPN output
- Normally open/normally closed function
- High switching frequency
- Short circuit protection (pulsed)
- Robust brass housing, nickel-plated with fine thread M8 x 1 mm
- Cable or connector
- Enclosure rating IP 67
- LED status indicator

IM 08 Short



Dimensional Drawing

dimensions in inches (mm)

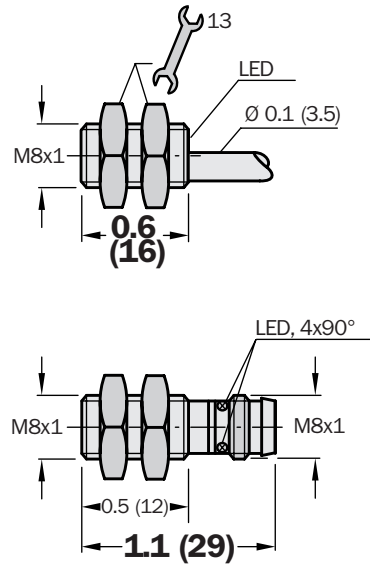

Accessories	page
Cables and connectors	908

Electrical and Mechanical Data

Operating voltage U_b	10...30 V DC
Ripple U_{pp}	$\leq 20\%$ of U_b
Voltage drop U_b	≤ 2.0 V max. at $I_a = 200$ mA
Power consumption (without load)	≤ 10 mA
Continuous current I_a	≤ 200 mA
Time delay before availability t_v	≤ 10 ms
Hysteresis H	10% of s_r
Repeatability R (U_b and T_a constant)	$\leq 5\%$ of s_r
Temperature drift	$\pm 10\%$ of s_r
EMC	to EN 60 947-5-2
Short circuit protection (pulsed)	Yes
Reverse polarity protection	Yes
Power-up pulse suppression	Yes
Enclosure rating to DIN 40050	IP 67
Shock and vibration stress	30 g, 11 ms, 10 to 55 Hz, 1 mm
Ambient temperature T_a	-13...167°F (-25...75°C)
Housing material	Brass, nickel-plated, plastic
Tightening torque	4 Nm
Connection cable	PVC, 3 x 0.14 mm ²

Selection Table

Sensing range S_n in (mm)	Installation in metal	Switching output	Output function	Switching frequency f in Hz	Connection type	Type	Part no.
0.06 (1.5)		PNP		5000	Cable 2 m	IM08-1B5PS-ZWK	6 020 111
0.06 (1.5)		NPN		5000	Cable 2 m	IM08-1B5NS-ZWK	6 020 173
0.06 (1.5)		PNP		5000	Connector M8 x 1 mm	IM08-1B5PS-ZTK	6 020 112
0.06 (1.5)		NPN		5000	Connector M8 x 1 mm	IM08-1B5NS-ZTK	6 020 176
0.06 (1.5)		PNP		5000	Connector M8 x 1 mm	IM08-1B5PO-ZTK	6 020 177

Connection Diagram

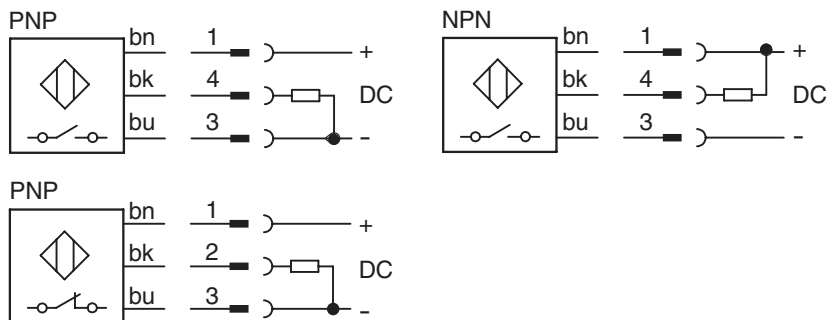

Wire color	Contact	Assignment
bn	brown	1 + V DC
bk	black	4 NO/NC
bu	blue	3 - V DC

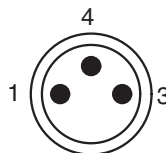

IM 08 Advanced

Inductive Proximity Sensors



IM 08 Advanced

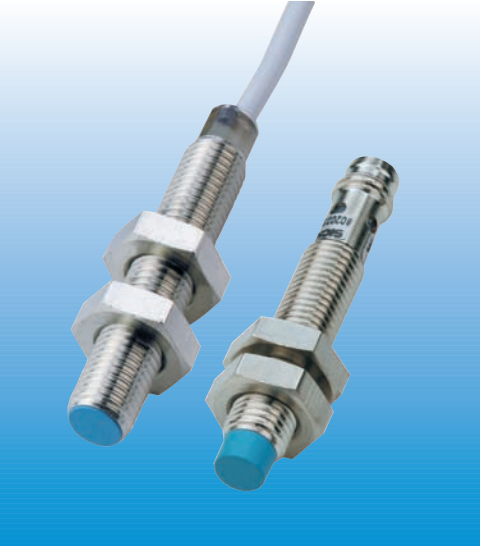

Highlights

- Enhanced sensing range
- Shielded or unshielded
- PNP or NPN output
- Normally open/normally closed function
- High switching frequency
- Short circuit protection (pulsed)
- Robust brass housing, nickel-plated with fine thread M8 x 1 mm
- Cable or connector
- Enclosure rating IP 67
- LED status indicator

Dimensional Drawing

dimensions in inches (mm)

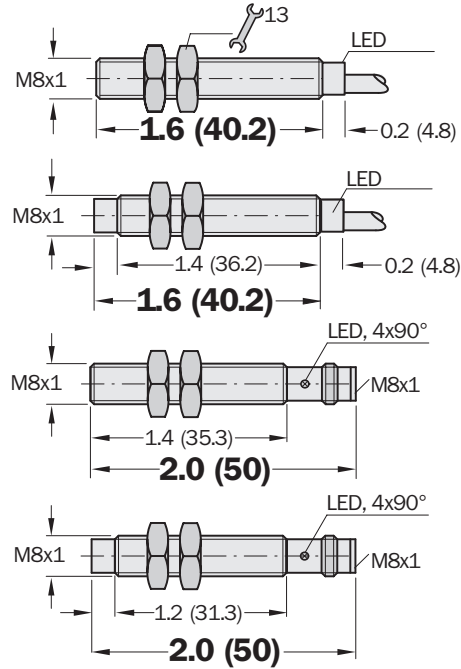

Accessories	page
Cables and connectors	908

Electrical and Mechanical Data

Operating voltage U_b	10...30 V DC
Ripple U_{pp}	$\leq 10\%$ of U_b
Voltage drop U_b	≤ 1.2 V at I_a max.
Power consumption (without load)	≤ 20 mA
Continuous current I_a	≤ 200 mA
Time delay before availability t_v	≤ 100 ms
Hysteresis H	2% - 15% of s_r
Repeatability R (U_b and T_a constant)	$\leq 5\%$ of s_r
Temperature drift	$\pm 10\%$ of s_r
EMC	to EN 60 947-5-2
Short circuit protection (pulsed)	Yes
Reverse polarity protection	Yes
Power-up pulse suppression	Yes
Enclosure rating to DIN 40050	IP 67
Shock and vibration stress	30 g, 11 ms, 10 to 55 Hz, 1 mm
Ambient temperature T_a	-13...158°F (-25...70°C)
Housing material	Brass, nickel-plated, plastic
Tightening torque	4 Nm
Connection cable	PVC, 3 x 0.14 mm ²

Selection Table

Sensing range S_n in (mm)	Installation in metal	Switching output	Output function	Switching frequency f in Hz	Connection type	Type	Part no.
0.08 (2)		PNP		3000	Cable 2 m	IM08-02BPS-ZW1	7 900 001
0.08 (2)		NPN		3000	Cable 2 m	IM08-02BNS-ZW1	7 900 002
0.08 (2)		PNP		3000	Cable 2 m	IM08-02BPO-ZW1	7 900 003
0.08 (2)		PNP		3000	Connector M8 x 1 mm	IM08-02BPS-ZT1	7 900 005
0.08 (2)		NPN		3000	Connector M8 x 1 mm	IM08-02BNS-ZT1	7 900 006
0.08 (2)		PNP		3000	Connector M8 x 1 mm	IM08-02BPO-ZT1	7 900 007
0.08 (2)		NPN		3000	Connector M8 x 1 mm	IM08-02BNO-ZT1	7 900 008
0.2 (4)		PNP		3000	Cable 2 m	IM08-04NPS-ZW1	7 900 009
0.2 (4)		NPN		3000	Cable 2 m	IM08-04NNS-ZW1	7 900 010
0.2 (4)		PNP		3000	Cable 2 m	IM08-04NPO-ZW1	7 900 011
0.2 (4)		PNP		3000	Connector M8 x 1 mm	IM08-04NPS-ZT1	7 900 013
0.2 (4)		NPN		3000	Connector M8 x 1 mm	IM08-04NNS-ZT1	7 900 014
0.2 (4)		PNP		3000	Connector M8 x 1 mm	IM08-04NPO-ZT1	7 900 015
0.2 (4)		NPN		3000	Connector M8 x 1 mm	IM08-04NNO-ZT1	7 900 016

Connection Diagram

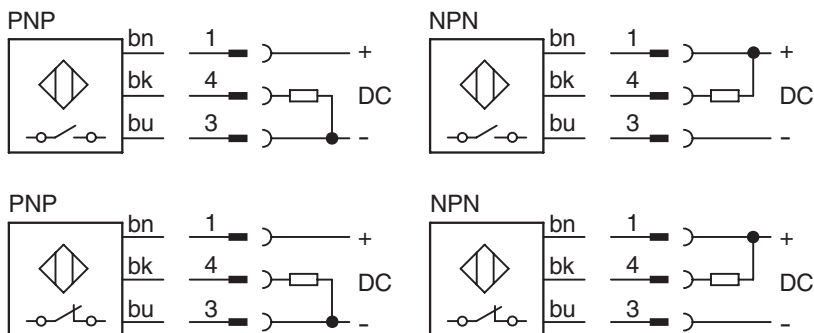

Wire color	Contact	Assignment
bn	brown	1 + V DC
bk	black	4 NO/NC
bu	blue	3 - V DC

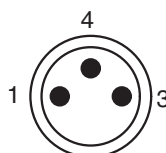

IM 08 Advanced Short

Inductive Proximity Sensors



Highlights

- Enhanced sensing range
- Shielded or unshielded
- PNP or NPN output
- Normally open/normally closed function
- High switching frequency
- Short circuit protection (pulsed)
- Robust brass housing, nickel-plated with fine thread M8 x 1 mm
- Cable or connector
- Enclosure rating IP 67
- LED status indicator

IM 08 Advanced Short



Dimensional Drawing

dimensions in inches (mm)

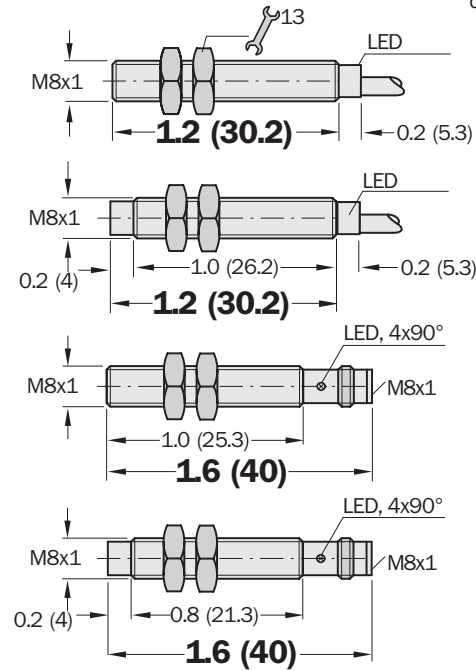

Accessories	page
Cables and connectors	908

Electrical and Mechanical Data

Operating voltage U_b	10...30 V DC
Ripple U_{pp}	$\leq 10\%$ of U_b
Voltage drop U_b	≤ 1.2 V at I_a max.
Power consumption (without load)	≤ 10 mA
Continuous current I_a	≤ 200 mA
Time delay before availability t_v	≤ 5 ms
Hysteresis H	1% - 20% of s_r
Repeatability R (U_b and T_a constant)	$\leq 5\%$ of s_r
Temperature drift	$\pm 10\%$ of s_r
EMC	to EN 60 947-5-2
Short circuit protection (pulsed)	Yes
Reverse polarity protection	Yes
Power-up pulse suppression	Yes
Enclosure rating to DIN 40050	IP 67
Shock and vibration stress	30 g, 11 ms, 10 to 55 Hz, 1 mm
Ambient temperature T_a	-13...158°F (-25...70°C)
Housing material	Brass, nickel-plated, plastic
Tightening torque	4 Nm
Connection cable	PVC, 3 x 0.14 mm ²

Selection Table

Sensing range S_n in (mm)	Installation in metal	Switching output	Output function	Switching frequency f in Hz	Connection type	Type	Part no.
0.08 (2)		PNP		3000	Cable 2 m	IM08-02BPS-ZWK	6 025 861
0.08 (2)		NPN		3000	Cable 2 m	IM08-02BNS-ZWK	6 025 862
0.08 (2)		PNP		3000	Connector M8 x 1 mm	IM08-02BPS-ZTK	6 025 863
0.08 (2)		NPN		3000	Connector M8 x 1 mm	IM08-02BNS-ZTK	6 025 864
0.08 (2)		PNP		3000	Connector M8 x 1 mm	IM08-02BPO-ZTK	6 025 865
0.08 (2)		NPN		3000	Connector M8 x 1 mm	IM08-02BNO-ZTK	6 025 866
0.2 (4)		PNP		2500	Cable 2 m	IM08-04NPS-ZWK	6 025 867
0.2 (4)		NPN		2500	Cable 2 m	IM08-04NNS-ZWK	6 025 868
0.2 (4)		PNP		2500	Connector M8 x 1 mm	IM08-04NPS-ZTK	6 025 869
0.2 (4)		NPN		2500	Connector M8 x 1 mm	IM08-04NNS-ZTK	6 025 870
0.2 (4)		PNP		2500	Connector M8 x 1 mm	IM08-04NPO-ZTK	6 025 871
0.2 (4)		NPN		2500	Connector M8 x 1 mm	IM08-04NNO-ZTK	6 025 872

Connection Diagram

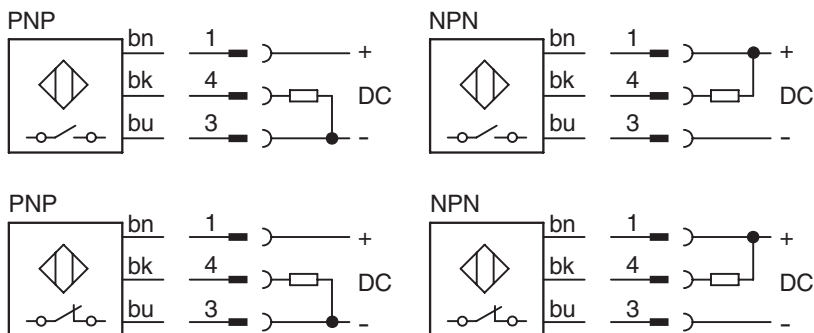

Wire color	Contact	Assignment
bn	brown	1 + V DC
bk	black	4 NO/NC
bu	blue	3 - V DC

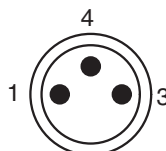

IM 08 Triple Sensing Range

Inductive Proximity Sensors



Highlights

- Triple sensing range
- Installation quasi flush or non-flush in metal
- Normally open function
- PNP or NPN output
- High switching frequency
- Short circuit protection (pulsed)
- Robust brass housing, nickel-plated with fine thread M8 x 1 mm
- Cable or connector
- Enclosure rating IP 67
- LED status indicator

IM 08 Triple Sensing Range

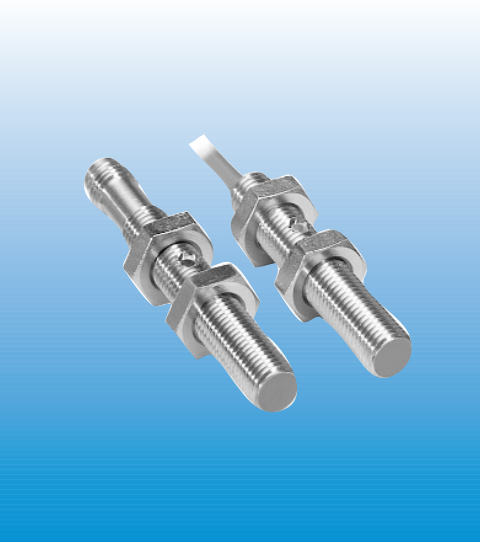

Dimensional Drawing

dimensions in inches (mm)

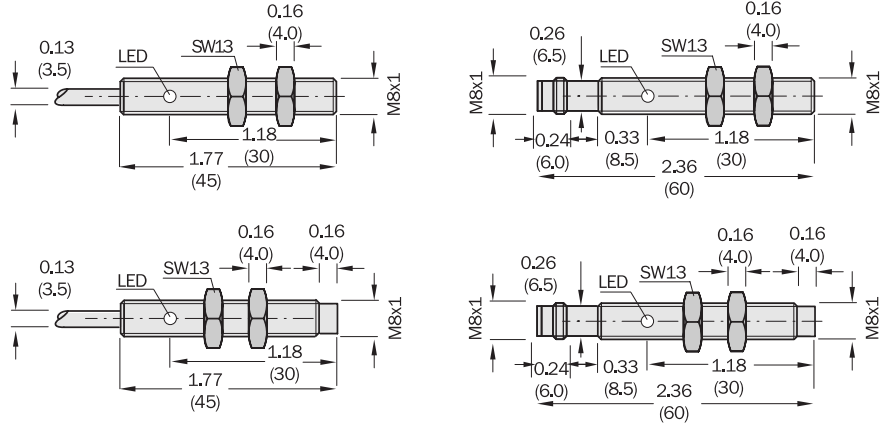

Accessories	page
Cables and connectors	908

Electrical and Mechanical Data

Operating voltage U_b	10...30 V DC
Ripple U_{ss}	$\leq 20\%$ of U_b
Voltage drop U_d (at I_a max.)	≤ 2 V at I_a max.
Power consumption (without load)	≤ 10 mA
Continuous current I_a	≤ 200 mA
Time delay before availability T_v	≤ 100 ms
Hysteresis H	1% - 5% of s_r (5% typ.)
Repeatability R (U_b and T_a constant)	$\leq 5\%$ of s_r
Temperature drift	$\pm 10\%$ of s_r
EMC	to EN 60 947-5-2
Short circuit protection (pulsed)	Yes
Reverse polarity protection	Yes
Power-up pulse suppression	Yes
Enclosure rating to EN 60529	IP 67
Shock and vibration stress	30 g, 11 ms, 10 to 55 Hz, 1 mm
Ambient temperature T_a	-13...158°F (-25...70°C)
Housing material	Brass, chrome-plated, plastic
Tightening torque	4 Nm
Connection cable	PVC, 3 x 0.14 mm ²

Selection Table

Sensing range S_n in (mm)	Installation in metal	Switching output	Output function	Switching frequency f in Hz	Connection type	Type	Part no.
0.12 (3)		PNP		1000	Cable 2 m	IM 08-03BPS-ZW1	6 027 505
0.12 (3)		PNP		1000	Connector M8 x 1 mm	IM08-03BPS-ZTI	6 025 574
0.24 (6)		PNP		500	Cable 2 m	IM08-06NPS-ZW1	6 027 506
0.24 (6)		NPN		500	Cable 2 m	IM08-06NNS-ZW1	6 027 507
0.24 (6)		PNP		500	Connector M8 x 1 mm	IM08-06NPS-ZTI	6 027 508

* Installation notes "quasi flush"

When mounting in conductible materials the sensors have to be installed with a distance A to the surface.

A Steel, metal = 1 mm / A Stainless steel = 0 mm

Connection Diagram

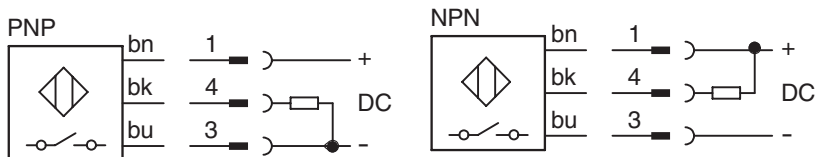

Wire color	Contact	Assignment
bn	brown	1 + V DC
bk	black	4 NO
bu	blue	3 - V DC

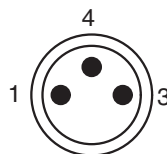

IM 08 NAMUR

Inductive Proximity Sensors



Highlights

- NAMUR to DIN 19 234
- High switching frequency
- Robust brass housing with nickel-plated fine thread M8 x 1
- Enclosure rating IP 67
- LED status indicator

IM 08 NAMUR

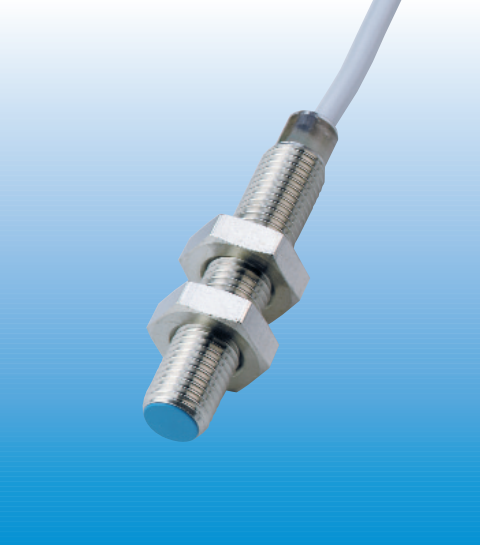

Dimensional Drawing

dimensions in inches (mm)

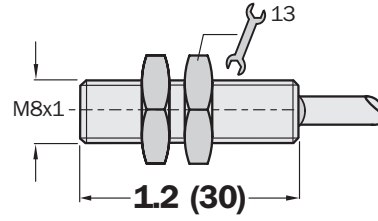

Accessories	page
Power supply	966



Electrical and Mechanical Data

Operating voltage U_b	5...25 V DC
Nominal voltage U_n	8.2 V DC
Power consumption, attenuated	≤ 1.0 mA
Power consumption, unattenuated	≥ 2.2 mA
Internal capacitance	≤ 80 nF
Internal inductance	≤ 110 μH
Cable resistance	≤ 50 Ω
Temperature drift	± 10% of s_r
EMC	to EN 60 947-5-2
Enclosure rating to EN 60529	IP 67
Shock and vibration stress	30 g, 11 ms, 10 to 55 Hz, 1 mm
Ambient temperature T_a	-13...158°F (-25...70°C)
Housing material	Brass, nickel-plated, plastic
Tightening torque	2.5 Nm
Connection cable	PVC, 2 x 0.14 mm ² , blue

Max. data for connecting isolating unit EN 2
EX or other approved isolating amplifier:

Short circuit current I_k max	50 mA
No load voltage U_o	15 V
Power loss P_{max}	180 mW

Selection Table

Sensing range S_n in (mm)	Installation in metal	Switching output	Output function	Switching frequency f in Hz	Connection type	Type	Part no.
0.04 (1)		NAMUR		2000	Cable 2 m	IM08-01B-N-ZW0	6 021 123

Connection Diagram

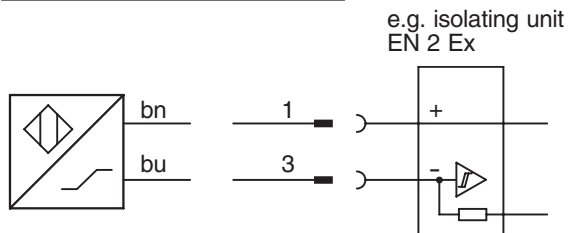

Wire color			Assignment
bn	braun	brown	+ V DC
bu	blau	blue	- V DC

IM 12 Standard

Inductive Proximity Sensors



Highlights

- Shielded or unshielded
- PNP or NPN output
- Normally open/normally closed function
- Short circuit protection (pulsed)
- Robust brass housing, nickel-plated with fine thread M12 x 1 mm
- Cable or connector
- Enclosure rating IP 67
- LED status indicator

IM 12 Standard



Dimensional Drawing

dimensions in inches (mm)

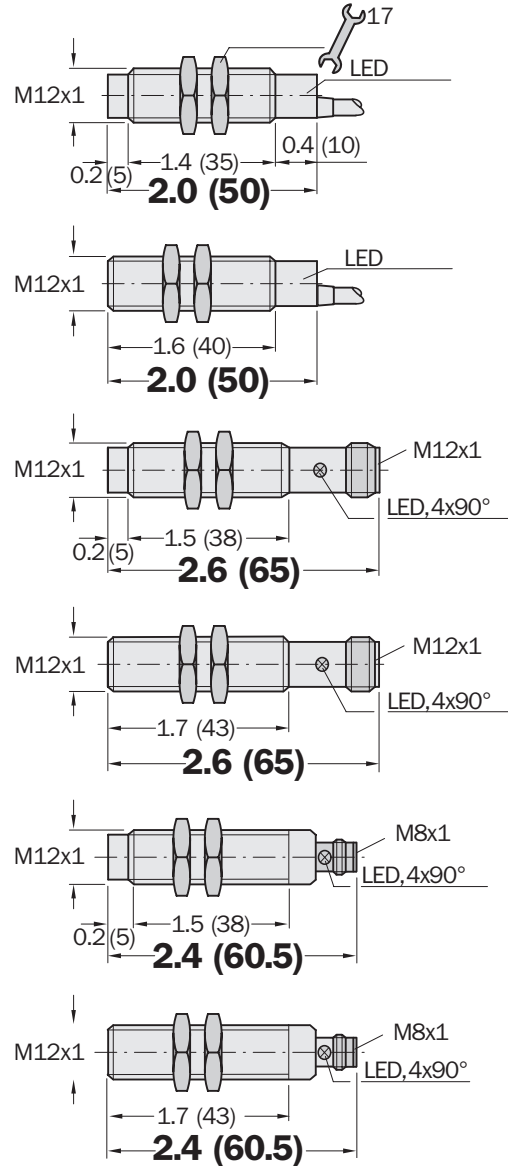

Accessories	page
Cables and connectors	908, 909
Mounting brackets	925

Electrical and Mechanical Data

Operating voltage U_b	10...30 V DC
Ripple U_{pp}	$\leq 10\%$
Voltage drop U_b	≤ 1.2 V at I_a max.
Power consumption (without load)	≤ 20 mA
Continuous current I_a	≤ 200 mA
Time delay before availability t_v	≤ 100 ms
Hysteresis H	2% - 10% of s_r
Repeatability R (U_b and T_a constant)	$\leq 2\%$ of s_r
Temperature drift	$\pm 10\%$ of s_r
EMC	to EN 60 947-5-2
Short circuit protection (pulsed)	Yes
Reverse polarity protection	Yes
Power-up pulse suppression	Yes
Enclosure rating to DIN 40050	IP 67
Shock and vibration stress	30 g, 11 ms, 10 to 55 Hz, 1 mm
Ambient temperature T_a	-13...158°F (-25...70°C)
Housing material	Brass, nickel-plated, plastic
Tightening torque	10 Nm
Connection cable	PVC, 3 x 0.22 mm ²

Selection Table

Sensing range S_n in (mm)	Installation in metal	Switching output	Output function	Switching frequency f in Hz	Connection type	Type	Part no.
0.08 (2)		PNP		2000	Cable 2 m	IM12-02BPS-ZW1	6 011 963
0.08 (2)		NPN		2000	Cable 2 m	IM12-02BNS-ZW1	6 011 964
0.08 (2)		PNP		2000	Cable 2 m	IM12-02BPO-ZW1	6 011 965
0.08 (2)		NPN		2000	Cable 2 m	IM12-02BNO-ZW1	6 011 966
0.08 (2)		PNP		2000	Connector M8 x 1 mm	IM12-02BPS-ZT1	6 011 967
0.08 (2)		NPN		2000	Connector M8 x 1 mm	IM12-02BNS-ZT1	6 011 968
0.08 (2)		PNP		2000	Connector M12 x 1 mm	IM12-02BPS-ZC1	6 011 971
0.08 (2)		NPN		2000	Connector M12 x 1 mm	IM12-02BNS-ZC1	6 011 972
0.08 (2)		PNP		2000	Connector M12 x 1 mm	IM12-02BPO-ZC1	6 011 973
0.08 (2)		NPN		2000	Connector M12 x 1 mm	IM12-02BNO-ZC1	6 011 974
0.2 (4)		PNP		2000	Cable 2 m	IM12-04NPS-ZW1	6 011 975
0.2 (4)		NPN		2000	Cable 2 m	IM12-04NNS-ZW1	6 011 976
0.2 (4)		PNP		2000	Cable 2 m	IM12-04NPO-ZW1	6 011 977
0.2 (4)		PNP		2000	Connector M8 x 1 mm	IM12-04NPS-ZT1	6 011 979
0.2 (4)		NPN		2000	Connector M8 x 1 mm	IM12-04NNS-ZT1	6 011 980
0.2 (4)		PNP		2000	Connector M12 x 1 mm	IM12-04NPS-ZC1	6 011 983
0.2 (4)		NPN		2000	Connector M12 x 1 mm	IM12-04NNS-ZC1	6 011 984
0.2 (4)		PNP		2000	Connector M12 x 1 mm	IM12-04NPO-ZC1	6 011 985

Connection Diagram

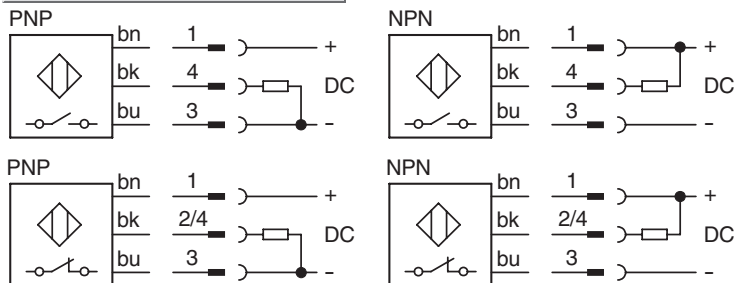

Wire color	Contact M8	Contact M12	Assignment
bn brown	1	1	+ V DC
bk black	4	2/4	NO/NC
bu blue	3	3	- V DC

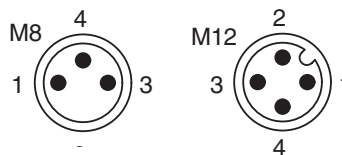

IM 12 Short

Inductive Proximity Sensors



Highlights

- Shielded or unshielded
- PNP or NPN output
- Normally open function
- High switching frequency
- Short circuit protection (pulsed)
- Robust brass housing, nickel-plated with fine thread M12 x 1 mm
- Cable or connector
- Enclosure rating IP 67
- LED status indicator

IM 12 Short



Dimensional Drawing

dimensions in inches (mm)

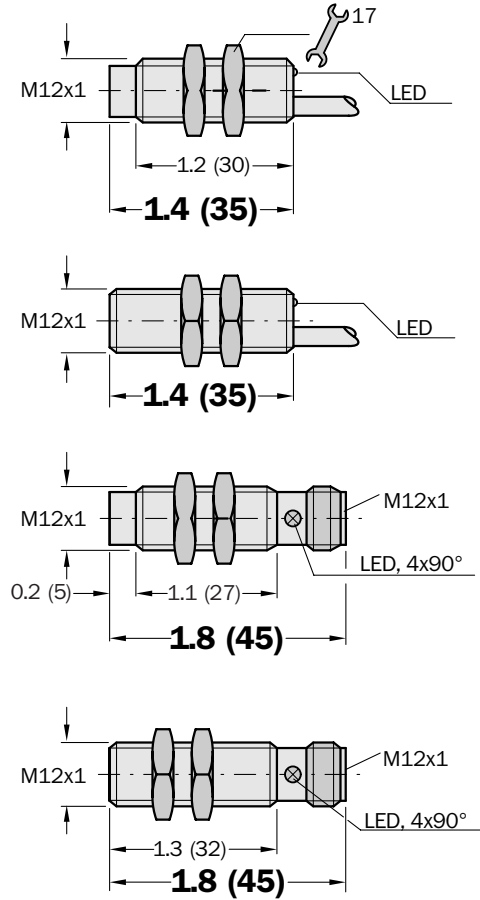

Accessories	page
Cables and connectors	909
Mounting brackets	925

Electrical and Mechanical Data

Operating voltage U_b	10...30 V DC
Ripple U_{pp}	$\leq 10\%$ of U_b
Voltage drop U_b	≤ 1.5 V at I_a max.
Power consumption (without load)	≤ 10 mA
Continuous current I_a	≤ 300 mA
Time delay before availability t_v	≤ 2 ms
Hysteresis H	1% - 10% of s_r
Repeatability R (U_b and T_a constant)	$\leq 1\%$ of s_r
Temperature drift	$\pm 10\%$ of s_r
EMC	to EN 60 947-5-2
Wire-break protection	Yes
Short circuit protection (pulsed)	Yes
Reverse polarity protection	Yes
Power-up pulse suppression	Yes
Enclosure rating to DIN 40050	IP 67
Shock and vibration stress	30 g, 11 ms, 10 to 55 Hz, 1 mm
Ambient temperature T_a	-13...167°F (-25...75°C)
Housing material	Brass, nickel-plated, plastic
Tightening torque	7.0 Nm
Connection cable	PUR-PVC, 3 x 0.25 mm ²

Selection Table

Sensing range S_n in (mm)	Installation in metal	Switching output	Output function	Switching frequency f in Hz	Connection type	Type	Part no.
0.08 (2)		PNP		3000	Cable 2 m	IM12-02BPS-ZUK	1 017 426
0.08 (2)		NPN		3000	Cable 2 m	IM12-02BNS-ZUK	1 017 438
0.08 (2)		PNP		3000	Connector M12 x 1 mm	IM12-02BPS-ZCK	1 017 428
0.08 (2)		NPN		3000	Connector M12 x 1 mm	IM12-02BNS-ZCK	1 017 440
0.2 (4)		PNP		3000	Cable 2 m	IM12-02NPS-ZUK	1 017 427
0.2 (4)		NPN		3000	Cable 2 m	IM12-02NNS-ZUK	1 017 439
0.2 (4)		PNP		3000	Connector M12 x 1 mm	IM12-02NPS-ZCK	1 017 429
0.2 (4)		NPN		3000	Connector M12 x 1 mm	IM12-02NNS-ZCK	1 017 441

Connection Diagram

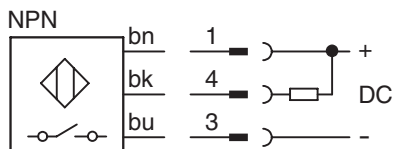
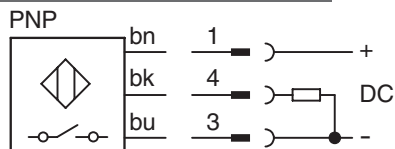

Wire color	Contact	Assignment
bn	brown	1 + V DC
bk	black	4 NO
bu	blue	3 - V DC

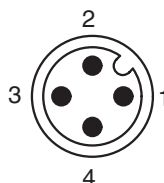

IM 12 2-wire

Inductive Proximity Sensors



Highlights

- Shielded or unshielded
- Normally open function
- Short circuit protection (pulsed)
- Robust brass housing, nickel-plated with fine thread M12 x 1 mm
- Cable or connector
- Enclosure rating IP 67
- LED status indicator

IM 12 2-wire



Dimensional Drawing

dimensions in inches (mm)

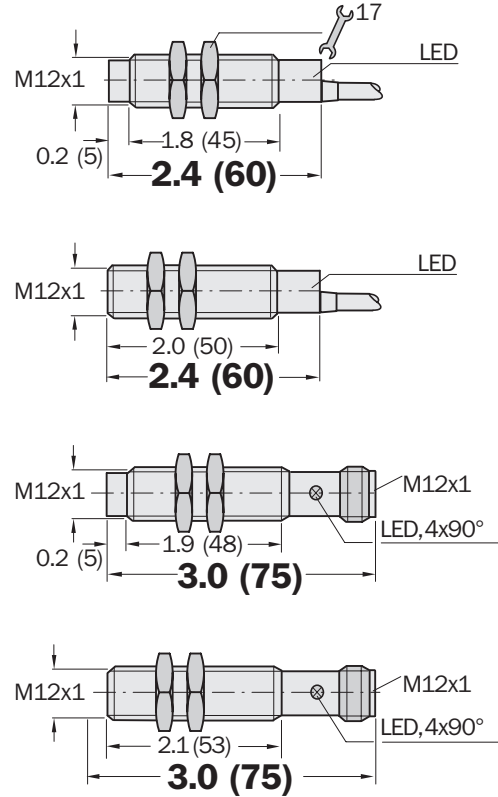

Accessories	page
Cables and connectors	909
Mounting brackets	925

Electrical and Mechanical Data

Operating voltage U_b	10...30 V DC
Ripple U_{pp}	$\leq 10\%$
Voltage drop U_b	≤ 2.8 V at I_a max.
Power consumption (without load)	≈ 3 mA
Continuous current I_a	≤ 100 mA
Time delay before availability t_v	≤ 0.8 ms
Hysteresis H	≤ 50 ms
Repeatability R (U_b and T_a constant)	2% - 10% of s_r
Temperature drift	$\leq 5\%$ of s_r
EMC	$\pm 10\%$ of s_r
Short circuit protection (pulsed)	to EN 60 947-5-2
Reverse polarity protection	Yes
Power-up pulse suppression	Yes
Enclosure rating to EN 60529	IP 67
Shock and vibration stress	30 g, 11 ms, 10 to 55 Hz, 1 mm
Ambient temperature T_a	-13...158°F (-25...70°C)
Housing material	Brass, nickel-plated, plastic
Tightening torque	10 Nm
Connection cable	PVC, 2 x 0.22 mm ²

Selection Table

Sensing range S_n in (mm)	Installation in metal	Output function	Switching frequency f in Hz	Connection type	Type	Part no.
0.08 (2)			1500	Cable 2 m	IM12-02BDS-ZW1	6 020 310
0.08 (2)			1500	Connector M12 x 1 mm	IM12-02BDS-ZC1	6 020 312
0.2 (4)			1500	Cable 2 m	IM12-04NDS-ZW1	6 020 314
0.2 (4)			1500	Connector M12 x 1 mm	IM12-04NDS-ZC1	6 020 316

Connection Diagram

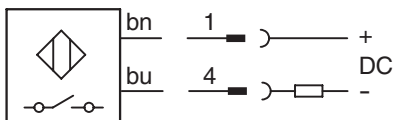

Wire color	Contact	Assignment
bn brown	1	+ V DC
bu blue	4	- V DC

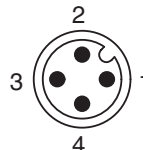

IM 12 Advanced

Inductive Proximity Sensors



IM 12 Advanced



Highlights

- Enhanced sensing range
- Shielded or unshielded
- PNP or NPN output
- Normally open/normally closed function
- High switching frequency
- Short circuit protection (pulsed)
- Robust brass housing, nickel-plated with fine thread M12 x 1 mm
- Cable or connector
- Enclosure rating IP 67
- LED status indicator

Dimensional Drawing

dimensions in inches (mm)

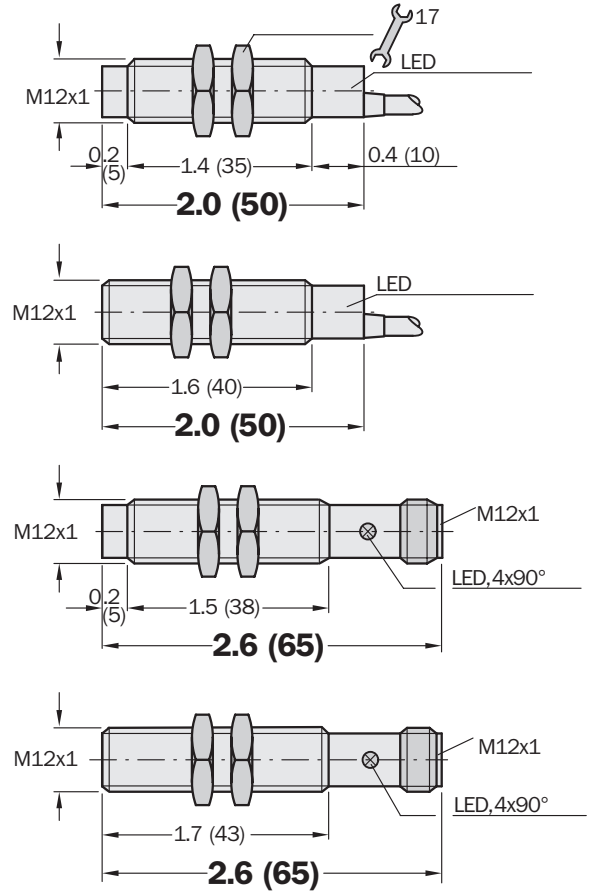

Accessories	page
Cables and connectors	909
Mounting brackets	925

Electrical and Mechanical Data

Operating voltage U_b	10...30 V DC
Ripple U_{pp}	$\leq 10\%$ of U_b
Voltage drop U_b	≤ 1.2 V at I_a max.
Power consumption (without load)	≤ 10 mA
Continuous current I_a	≤ 200 mA
Time delay before availability t_v	≤ 100 ms
Hysteresis H	1% - 15% of s_r
Repeatability R (U_b and T_a constant)	$\leq 5\%$ of s_r
Temperature drift	$\pm 10\%$ of s_r
EMC	to EN 60 947-5-2
Wire-break protection	Yes
Short circuit protection (pulsed)	Yes
Reverse polarity protection	Yes
Power-up pulse suppression	Yes
Enclosure rating to DIN 40050	IP 67
Shock and vibration stress	30 g, 11 ms, 10 to 55 Hz, 1 mm
Ambient temperature T_a	-13...158°F (-25...70°C)
Housing material	Brass, nickel-plated, plastic
Tightening torque	10 Nm
Connection cable	PVC, 3 x 0.22 mm ²

Selection Table

Sensing range S_n in (mm)	Installation in metal	Switching output	Output function	Switching frequency f in Hz	Connection type	Type	Part no.
0.2 (4)		PNP		1000	Cable 2 m	IM12-04BPS-ZW1	7 900 033
0.2 (4)		NPN		1000	Cable 2 m	IM12-04BNS-ZW1	7 900 034
0.2 (4)		PNP		1000	Cable 2 m	IM12-04BPO-ZW1	7 900 035
0.2 (4)		PNP		1000	Connector M12 x 1 mm	IM12-04BPS-ZC1	7 900 037
0.2 (4)		NPN		1000	Connector M12 x 1 mm	IM12-04BNS-ZC1	7 900 038
0.2 (4)		PNP		1000	Connector M12 x 1 mm	IM12-04BPO-ZC1	7 900 039
0.3 (8)		PNP		1000	Cable 2 m	IM12-08NPS-ZW1	7 900 041
0.3 (8)		NPN		1000	Cable 2 m	IM12-08NNS-ZW1	7 900 042
0.3 (8)		PNP		1000	Cable 2 m	IM12-08NPO-ZW1	7 900 043
0.3 (8)		NPN		1000	Cable 2 m	IM12-08NNO-ZW1	7 900 044
0.3 (8)		PNP		1000	Connector M12 x 1 mm	IM12-08NPS-ZC1	7 900 045
0.3 (8)		NPN		1000	Connector M12 x 1 mm	IM12-08NNS-ZC1	7 900 046
0.3 (8)		PNP		1000	Connector M12 x 1 mm	IM12-08NPO-ZC1	7 900 047

Connection Diagram

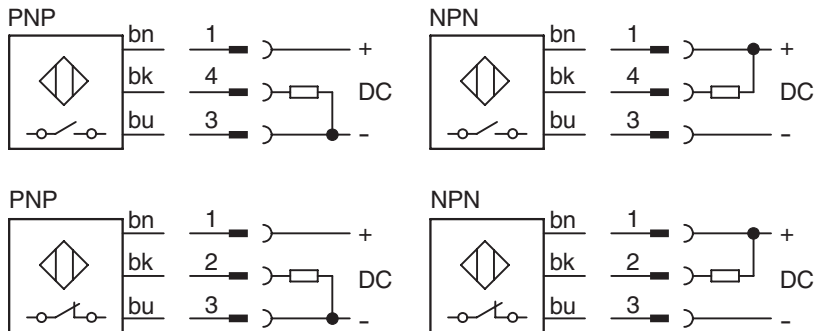

Wire color	Contact	Assignment
bn	brown	1 + V DC
bk	black	2/4 NO/NC
bu	blue	3 - V DC

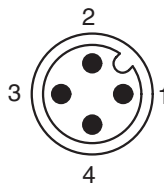

IM 12 Advanced Short

Inductive Proximity Sensors



Highlights

- Enhanced sensing range
- Short circuit protection (pulsed)
- Shielded or unshielded
- Robust brass housing, nickel-plated with fine thread M12 x 1 mm
- PNP or NPN output
- Cable or connector
- Normally open/normally closed function
- Enclosure rating IP 67
- High switching frequency
- LED status indicator

IM 08 Advanced Short



Dimensional Drawing

dimensions in inches (mm)

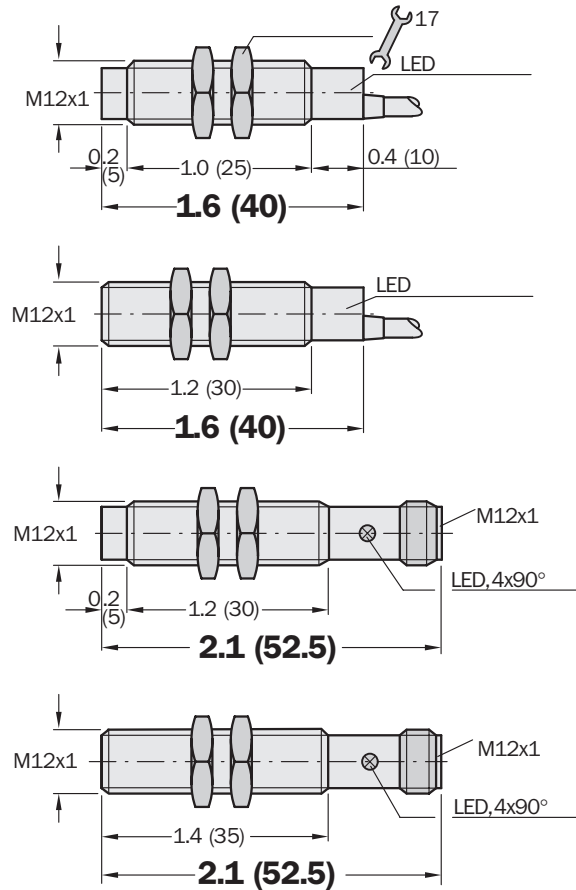

Accessories	page
Cables and connectors	909
Mounting brackets	925

Electrical and Mechanical Data

Operating voltage U_b	10...30 V DC
Ripple U_{pp}	$\leq 10\%$ of U_b
Voltage drop U_b	≤ 1.5 V at I_a max.
Power consumption (without load)	≤ 10 mA
Continuous current I_a	≤ 300 mA
Time delay before availability t_v	≤ 100 ms
Hysteresis H	1% - 15% of s_r
Repeatability R (U_b and T_a constant)	$\leq 5\%$ of s_r
Temperature drift	$\pm 10\%$ of s_r
EMC	to EN 60 947-5-2
Wire-break protection	Yes
Short circuit protection (pulsed)	Yes
Reverse polarity protection	Yes
Power-up pulse suppression	Yes
Enclosure rating to DIN 40050	IP 67
Shock and vibration stress	30 g, 11 ms, 10 to 55 Hz, 1 mm
Ambient temperature T_a	-13...168°F (-25...75°C)
Housing material	Brass, nickel-plated, plastic
Tightening torque	7 Nm
Connection cable	PVC, 3 x 0.22 mm ²

Selection Table

Sensing range S_n in (mm)	Installation in metal	Switching output	Output function	Switching frequency f in Hz	Connection type	Type	Part no.
0.2 (4)		PNP		2000	Cable 2 m	IM12-04BPS-ZWK	6 025 682
0.2 (4)		NPN		2000	Cable 2 m	IM12-04BNS-ZWK	6 025 683
0.2 (4)		PNP		2000	Connector M12 x 1 mm	IM12-04BPS-ZCK	6 025 679
0.2 (4)		NPN		2000	Connector M12 x 1 mm	IM12-04BNS-ZCK	6 025 681
0.2 (4)		PNP		2000	Connector M12 x 1 mm	IM12-04BPO-ZCK	6 025 680
0.2 (4)		NPN		2000	Connector M12 x 1 mm	IM12-04BNO-ZCK	6 025 859
0.3 (8)		PNP		2000	Cable 2 m	IM12-08NPS-ZWK	6 025 684
0.3 (8)		NPN		2000	Cable 2 m	IM12-08NNS-ZWK	6 025 685
0.3 (8)		PNP		2000	Connector M12 x 1 mm	IM12-08NPS-ZCK	6 025 686
0.3 (8)		NPN		2000	Connector M12 x 1 mm	IM12-08NNS-ZCK	6 025 687
0.3 (8)		PNP		2000	Connector M12 x 1 mm	IM12-08NPO-ZCK	6 025 688
0.3 (8)		NPN		2000	Connector M12 x 1 mm	IM12-08NNO-ZCK	6 025 860

Connection Diagram

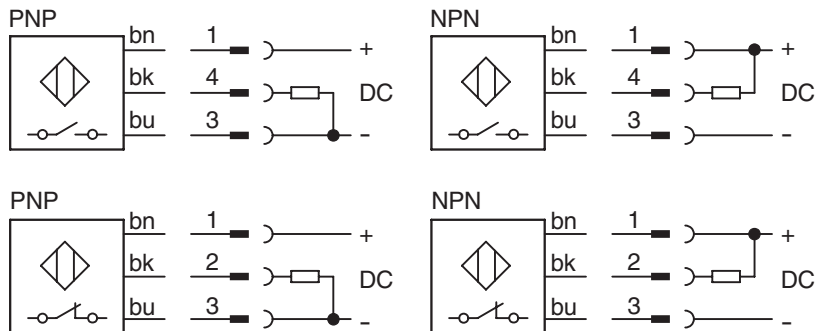

Wire color	Contact	Assignment
bn	brown	1 + V DC
bk	black	2/4 NO/NC
bu	blue	3 - V DC

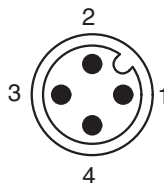

IM 12 Triple Sensing Range

Inductive Proximity Sensors



Highlights

- Triple sensing range
- Installation quasi or non-flush in metal
- Normally open function/normally closed function
- PNP or NPN output
- High switching frequency
- Short circuit protection (pulsed)
- Robust brass housing, nickel-plated with fine thread M8 x 1 mm
- Cable or connector
- Enclosure rating IP 67
- LED status indicator

IM 12 Triple Sensing Range

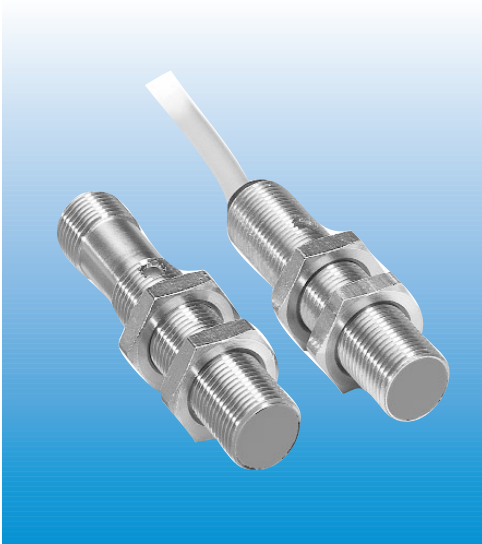

Dimensional Drawing

dimensions in inches (mm)

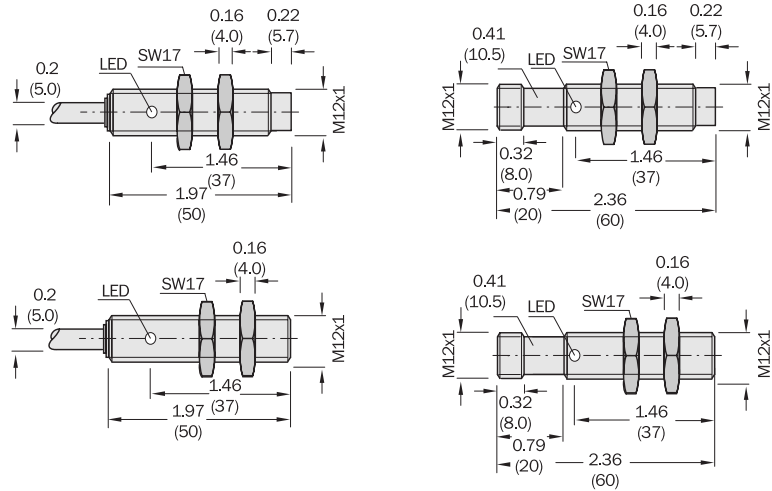

Accessories	page
Cables and connectors	909
Mounting brackets	925

Electrical and Mechanical Data

Operating voltage U_b	10...30 V DC
Ripple U_{ss}	$\leq 20\%$ of U_b
Voltage drop U_d (at I_a max.)	≤ 2 V at I_a max.
Power consumption (without load)	≤ 10 mA
Continuous current I_a	≤ 200 mA
Time delay before availability T_v	≤ 100 ms
Hysteresis H	1% - 5% of s_r (5% typ.)
Repeatability R (U_b and T_a constant)	$\leq 5\%$ of s_r
Temperature drift	$\pm 10\%$ of s_r
EMC	to EN 60 947-5-2
Short circuit protection (pulsed)	Yes
Reverse polarity protection	Yes
Power-up pulse suppression	Yes
Enclosure rating to EN 60529	IP 67
Shock and vibration stress	30 g, 11 ms, 10 to 55 Hz, 1 mm
Ambient temperature T_a	-13...158°F (-25...70°C)
Housing material	Brass, chrome-plated, plastic
Tightening torque	10 Nm
Connection cable	PVC, 3 x 0.34 mm ²

Selection Table

Sensing range S_n in (mm)	Installation in metal	Switching output	Output function	Switching frequency f in Hz	Connection type	Type	Part no.
0.24 (6)		PNP		800	Cable 2 m	IM 12-06BPS-ZW1	6 027 509
0.24 (6)		PNP		800	Cable 2 m	IM12-06BPO-ZWI	6 027 510
0.24 (6)		PNP		800	Connector M12 x 1 mm	IM12-06BPS-ZC1	6 027 511
0.4 (10)		PNP		400	Cable 2 m	IM12-10NPS-ZW1	6 027 512
0.4 (10)		NPN		400	Cable 2 m	IM12-10NNS-ZW1	6 027 513
0.4 (10)		PNP		400	Connector M12 x 1 mm	IM12-10NPS-ZC1	6 027 514

* Installation notes "quasi flush"

When mounting in conductible materials the sensors have to be installed with a distance A to the surface.

A Steel, metal = 2 mm / A Stainless steel = 1 mm

Connection Diagram

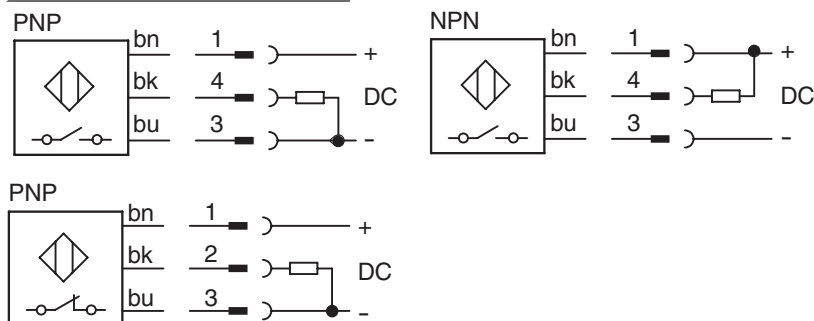

Wire color	Contact	Assignment
bn	1	+ V DC
bk	2/4	NC/NO
bu	3	- V DC

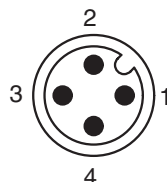

IM 12 Harsh Environment

Inductive Proximity Sensors



Highlights

- For harsh environment, resistant to most cutting oils
- Enclosure rating IP 68
- Shielded or unshielded
- PNP or NPN output
- Complementary output function
- Short circuit protection (pulsed)
- Robust brass housing, nickel-plated with fine thread M12 x 1 mm
- Internal enclosure housing in technopolymer
- LED status indicator (NO function)

IM 12 Harsh environment



Dimensional Drawing

dimensions in inches (mm)

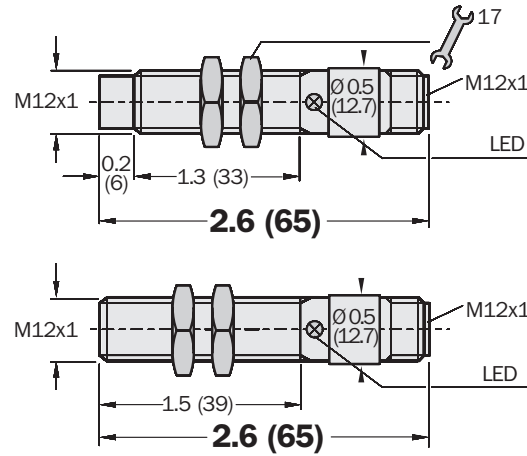

Accessories	page
Cables and connectors	909
Mounting brackets	925

Electrical and Mechanical Data

Operating voltage U_b	10...30 V DC
Ripple U_{pp}	$\leq 10\%$
Voltage drop U_b	≤ 1.2 V at I_a max.
Power consumption (without load)	≤ 20 mA
Continuous current I_a	≤ 100 mA
Time delay before availability t_v	≤ 100 ms
Hysteresis H	2% - 10% of s_r
Repeatability R (U_b and T_a constant)	$\leq 5\%$ of s_r
Temperature drift	$\pm 10\%$ of s_r
EMC	to EN 60 947-5-2
Short circuit protection (pulsed)	Yes
Reverse polarity protection	Yes
Power-up pulse suppression	Yes
Enclosure rating	IP 68
Shock and vibration stress	30 g, 11 ms, 10 to 55 Hz, 1 mm
Ambient temperature T_a	-13...158°F (-25...70°C)
Housing material	Brass, nickel-plated, plastic
Tightening torque	10 Nm

Selection Table

Sensing range S_n in (mm)	Installation in metal	Switching output	Output function	Switching frequency f in Hz	Connection type	Type	Part no.
0.08 (2)		PNP	 complementary	2000	Connector M12 x 1 mm	IM12-02BPP-ZC1	7 902 923
0.08 (2)		NPN	 complementary	2000	Connector M12 x 1 mm	IM12-02BNP-ZC1	7 902 924
0.2 (4)		PNP	 complementary	2000	Connector M12 x 1 mm	IM12-04NPP-ZC1	7 902 925
0.2 (4)		NPN	 complementary	2000	Connector M12 x 1 mm	IM12-04NPN-ZC1	7 902 926

Connection Diagram

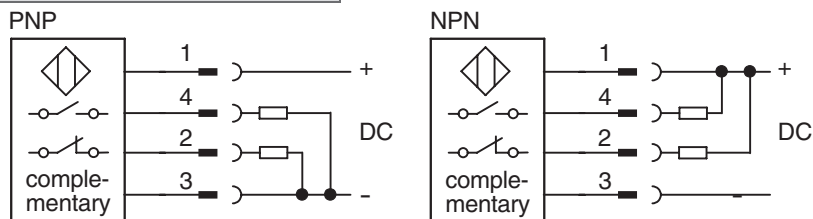

Wire color	Contact	Assignment
bn brown	1	+ V DC
wh white	2	NC
bu blue	3	- V DC
bk black	4	NO

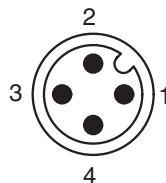

IM 12 QuadProx

Inductive Proximity Sensors



Highlights

- Programmable output functions in one sensor: PNP/NO, PNP/NC, NPN/NO, NPN/NC
- Robust brass housing, nickel-plated with fine thread M12 x 1 mm
- Shielded or unshielded
- Cable or connector
- Enclosure rating IP 67
- LED status indicator (NO function)
- Short circuit protection

IM 12 QuadProx

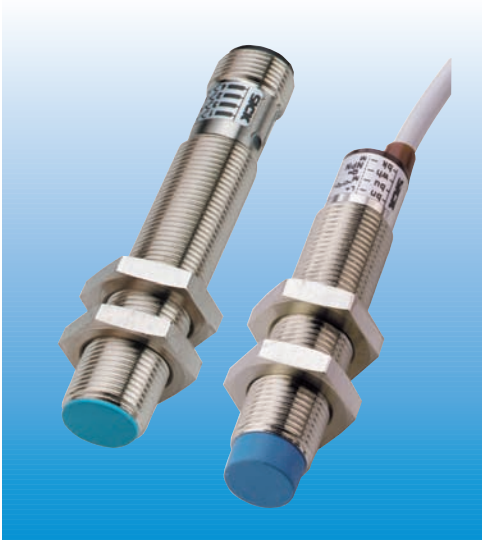

Dimensional Drawing

dimensions in inches (mm)

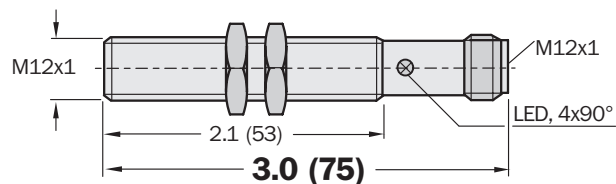
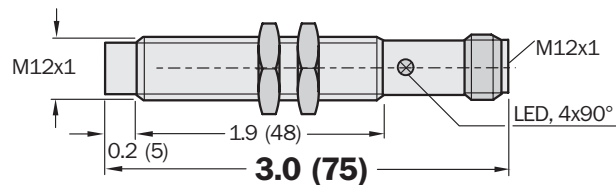
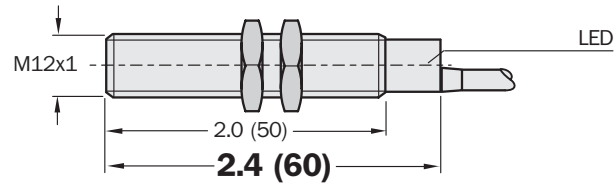
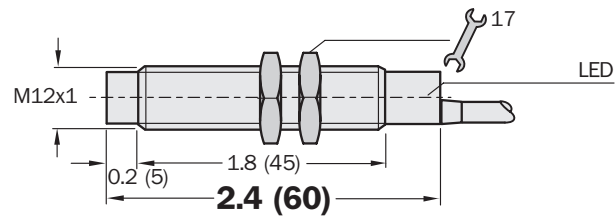

Accessories	page
Cables and connectors	909
Mounting brackets	925

Electrical and Mechanical Data

Operating voltage U_b	10...30 V DC
Ripple U_{pp}	$\leq 10\%$
Voltage drop U_b	≤ 1.2 V at I_a max.
Power consumption (without load)	≤ 30 mA
Continuous current I_a	≤ 100 mA
Time delay before availability t_v	≤ 250 ms
Hysteresis H	2% - 10% of s_r
Repeatability R (U_b and T_a constant)	$\leq 5\%$ of s_r
Temperature drift	$\pm 10\%$ of s_r
EMC	to EN 60 947-5-2
Short circuit protection (pulsed)	Yes
Reverse polarity protection	Yes
Power-up pulse suppression	Yes
Enclosure rating to DIN 40050	IP 67
Shock and vibration stress	30 g, 11 ms, 10 to 55 Hz, 1 mm
Ambient temperature T_a	-13...158°F (-25...70°C)
Housing material	Brass, nickel-plated, plastic
Tightening torque	15 Nm
Connection cable	PVC, 4 x 0.22 mm ²

Selection Table

Sensing range S_n in (mm)	Installation in metal	Switching output	Output function	Switching frequency f in Hz	Connection type	Type	Part no.
0.08 (2)		PNP/NPN config.		1000	Cable 2 m	IM12-02BCP-ZW1	7 902 927
0.08 (2)		PNP/NPN config.		1000	Connector M12 x 1 mm	IM12-02BCP-ZC1	7 902 928
0.2 (4)		PNP/NPN config.		1000	Cable 2 m	IM12-04NCP-ZW1	7 902 929
0.2 (4)		PNP/NPN config.		1000	Connector M12 x 1 mm	IM12-04NCP-ZC1	7 902 930

Connection Diagram

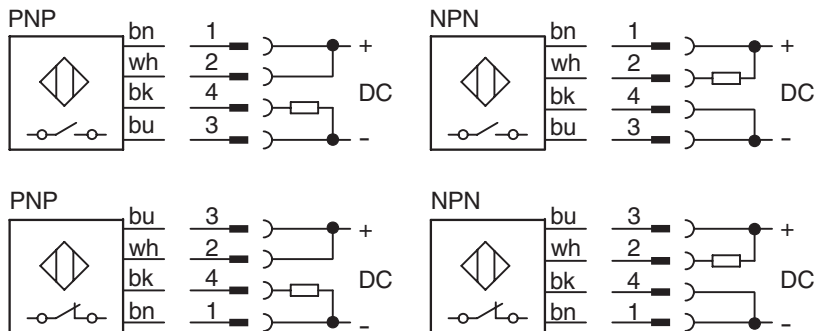

Wire color	Contact	Configurable output function				
		PNP		NPN		
bn	brown	1	+V DC	-V DC	+V DC	-V DC
wh	white	2	+V DC	+V DC	NO	NC
bu	blue	3	-V DC	+V DC	-V DC	+V DC
bk	black	4	NO	NC	-V DC	-V DC

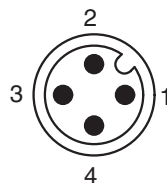

IM 12 Universal

Inductive Proximity Sensors



Highlights

- Shielded or unshielded
- Enclosure rating IP 67
- Normally open/normally closed function
- LED status indicator
- Robust brass housing, nickel-plated with fine thread M12 x 1 mm

IM 12



Dimensional Drawing

dimensions in inches (mm)

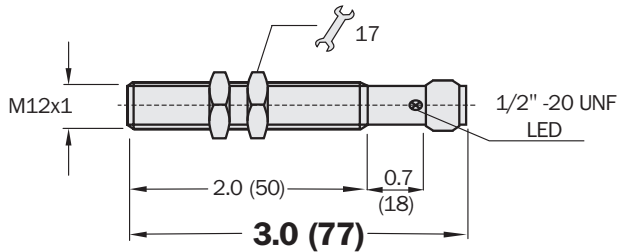
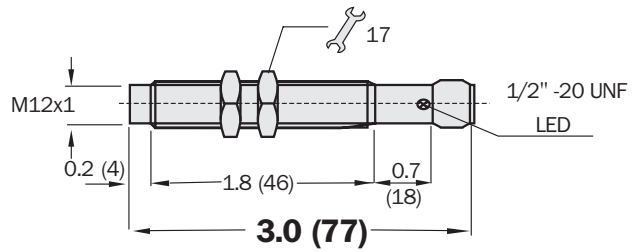
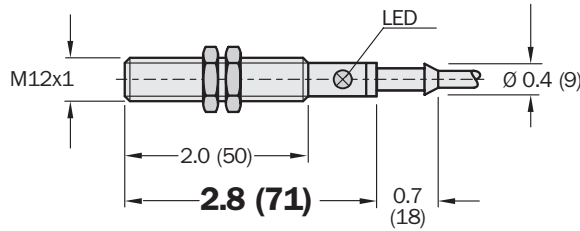
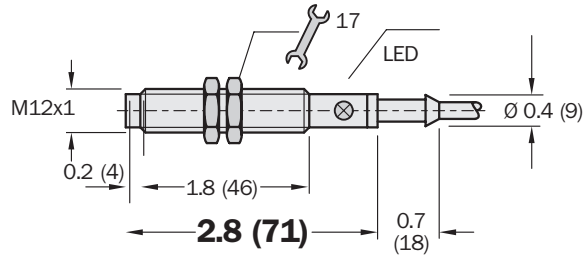

Accessories	page
Cables and connectors	909
Mounting brackets	925

Electrical and Mechanical Data

Operating voltage U_b	90...250 V AC
Voltage drop U_b	≤ 8.5 V AC at I_a max.
Continuous current I_a	≤ 250 mA AC (... + 50 °C), ≤ 200 mA AC (... + 80 °C)
Peak current I_k	0.9 A (20 ms/0.5 Hz)
Min. load current	8 mA
Residual current	≤ 3 mA (250 V AC), ≤ 1.5 mA (120 V AC)
Time delay before availability t_v	approx.10 ms
Hysteresis H	1% - 15% of s_r
Repeatability R (U_b and T_a constant)	$\leq 10\%$ of s_r
Temperature drift	$\pm 10\%$ of s_r
EMC	to EN 60 947-5-2
Wire-break protection	-
Short circuit protection (pulsed)	-
Reverse polarity protection	-
Power-up pulse suppression	Yes
Enclosure rating to DIN 40050	IP 67
Protection class	<input type="checkbox"/>
Shock and vibration stress	30 g, 11 ms, 10 to 55 Hz, 1 mm
Ambient temperature T_a	13...176°F (-25...80°C)
Housing material	Brass, nickel-plated, plastic
Tightening torque	7 Nm
Connection cable	PUR-PVC, 2 x 0.5 mm ²

Selection Table

Sensing range S_n in (mm)	Installation in metal	Output function	Switching frequency f in Hz	Connection type	Type	Part no.
0.08 (2)			25	Cable 2 m	IM12-02BAS-ZU0	7 902 118
0.08 (2)			25	Cable 2 m	IM12-02BA0-ZU0	7 902 119
0.08 (2)			25	Connector Micro AC	IM12-02BAS-ZZ0	6 020 627
0.2 (4)			25	Cable 2 m	IM12-04NAS-ZU0	7 902 120
0.2 (4)			25	Cable 2 m	IM12-04NA0-ZU0	7 902 121
0.2 (4)			25	Connector Micro AC	IM12-04NAS-ZZ0	6 020 628

Connection Diagram

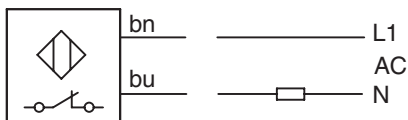
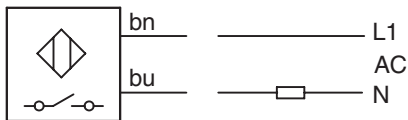

Cable version	Connector versions	Contact	Assignment
bn	red/white	3	L1
bu	red/blk	2	N
	grn	1	NC

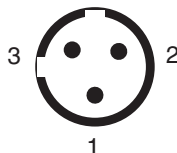

IM 12 NAMUR

Inductive Proximity Sensors



Highlights

- Shielded or unshielded
- NAMUR to DIN 19 234
- High switching frequency
- Robust brass housing with nickel-plated fine thread M8 x 1
- Enclosure rating IP 67
- LED status indicator

IM 12 NAMUR

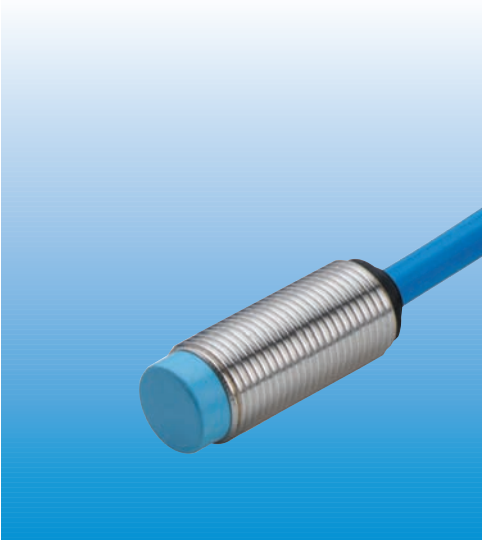

Dimensional Drawing

dimensions in inches (mm)

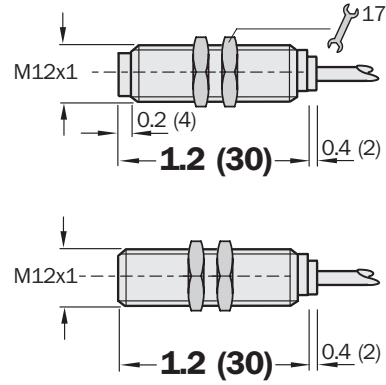

Accessories	page
Mounting brackets	925
Power supply	966

Electrical and Mechanical Data

Operating voltage U_b	5...25 V DC
Nominal voltage U_n	8.2 V DC
Power consumption, attenuated	≤ 1.0 mA
Power consumption, unattenuated	≥ 2.2 mA
Internal capacitance	≤ 230 nF
Internal inductance	≤ 380 μ H
Cable resistance	≤ 50 Ω
Temperature drift	$\pm 10\%$ of s_r
EMC	to EN 60 947-5-2
Short-circuit protected	Yes
Reverse polarity protected	Yes
Enclosure rating to EN 60529	IP 67
Shock and vibration stress	30 g, 11 ms, 10 to 55 Hz, 1 mm
Ambient temperature T_a	-13...158°F (-25...70°C)
Housing material	Brass, nickel-plated, plastic
Tightening torque	7.0 Nm
Connection cable	PVC, 2 x 0.34 mm ² , blue
Max. data for connecting isolating unit EN 2 EX or other approved isolating amplifier:	
Short circuit current I_k max	50 mA
No load voltage U_o	15 V
Power loss P_{max}	180 mW

Selection Table

Sensing range S_n in (mm)	Installation in metal	Switching output	Output function	Switching frequency f in Hz	Connection type	Type	Part no.
0.08 (2)		NAMUR		1200	Cable 2 m	IM12-02B-N-ZW0	6 021 124
0.2 (4)		NAMUR		1500	Cable 2 m	IM12-04N-N-ZW0	6 021 125

Connection Diagram

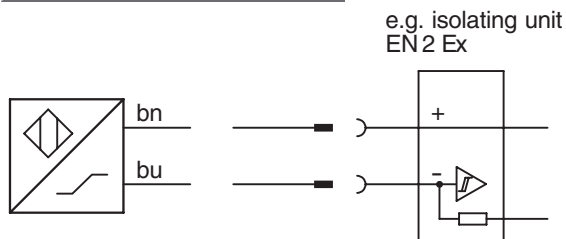

Wire color			Assignment
bn	braun	brown	+ V DC
bu	blau	blue	- V DC

IM 18 Standard

Inductive Proximity Sensors



Highlights

- Shielded or unshielded
- PNP or NPN output
- Normally open/normally closed function
- Short circuit protection (pulsed)
- Robust brass housing, nickel-plated with fine thread M18 x 1 mm
- Cable or connector
- Enclosure rating IP 67
- LED status indicator

IM 18 Standard



Dimensional Drawing

dimensions in inches (mm)

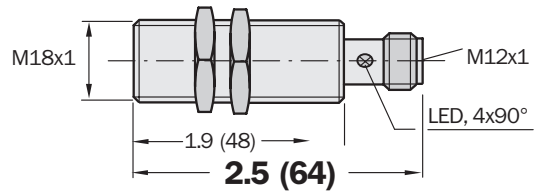
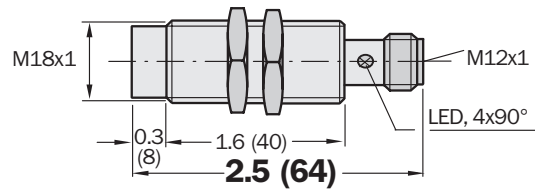
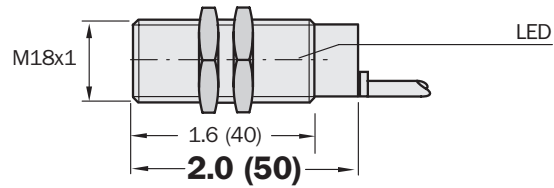
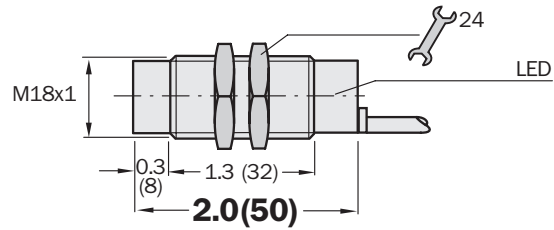

Accessories	page
Cables and connectors	909
Mounting brackets	925, 926

Electrical and Mechanical Data

Operating voltage U_b	10...30 V DC
Ripple U_{pp}	$\leq 10\%$
Voltage drop U_b	≤ 1 V at I_a max.
Power consumption (without load)	≤ 20 mA
Continuous current I_a	≤ 400 mA
Time delay before availability t_v	≤ 100 ms
Hysteresis H	2% - 10% of s_r
Repeatability R (U_b and T_a constant)	$\leq 2\%$ of s_r
Temperature drift	$\pm 10\%$ of s_r
EMC	to EN 60 947-5-2
Short circuit protection (pulsed)	Yes
Reverse polarity protection	Yes
Power-up pulse suppression	Yes
Enclosure rating to DIN 40050	IP 67
Shock and vibration stress	30 g, 11 ms, 10 to 55 Hz, 1 mm
Ambient temperature T_a	-13...158°F (-25...70°C)
Housing material	Brass, nickel-plated, plastic
Tightening torque	30 Nm
Connection cable	PVC, 3 x 0.34 mm ²

Selection Table

Sensing range S_n in (mm)	Installation in metal	Switching output	Output function	Switching frequency f in Hz	Connection type	Type	Part no.
0.2 (5)		PNP		600	Cable 2 m	IM18-05BPS-ZW1	6 011 987
0.2 (5)		NPN		600	Cable 2 m	IM18-05BNS-ZW1	6 011 988
0.2 (5)		PNP		600	Connector M12 x 1 mm	IM18-05BPS-ZC1	6 011 991
0.2 (5)		NPN		600	Connector M12 x 1 mm	IM18-05BNS-ZC1	6 011 992
0.2 (5)		PNP		600	Connector M12 x 1 mm	IM18-05BPO-ZC1	6 011 993
0.3 (8)		PNP		600	Cable 2 m	IM18-08NPS-ZW1	6 011 995
0.3 (8)		NPN		600	Cable 2 m	IM18-08NNS-ZW1	6 011 996
0.3 (8)		NPN		600	Cable 2 m	IM18-08NNO-ZW1	6 011 998
0.3 (8)		PNP		600	Connector M12 x 1 mm	IM18-08NPS-ZC1	6 011 999
0.3 (8)		NPN		600	Connector M12 x 1 mm	IM18-08NNS-ZC1	6 012 000
0.3 (8)		PNP		600	Connector M12 x 1 mm	IM18-08NPO-ZC1	6 012 001

Connection Diagram

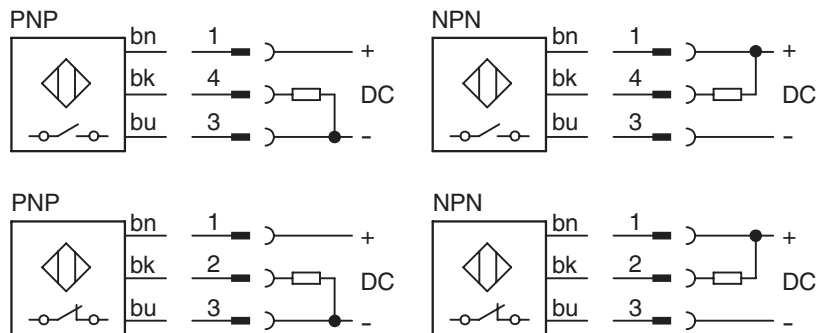

Wire color	Contact	Assignment
bn	brown	1 + V DC
bk	black	2/4 NO/NC
bu	blue	3 - V DC

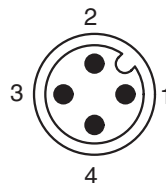

IM 18 Short

Inductive Proximity Sensors



Highlights

- Shielded or unshielded
- PNP or NPN output
- Normally open function
- Short circuit protection (pulsed)
- Robust brass housing, nickel-plated with fine thread M18 x 1 mm
- Cable or connector
- Enclosure rating IP 67
- LED status indicator

IM 18 Short



Dimensional Drawing

dimensions in inches (mm)

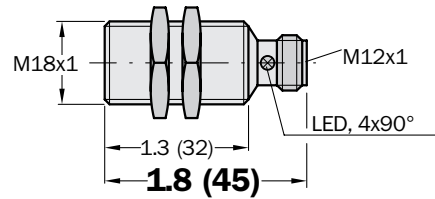
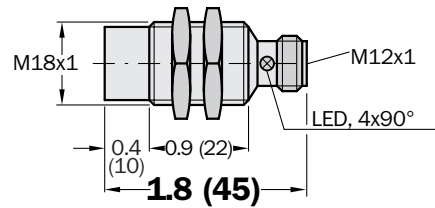
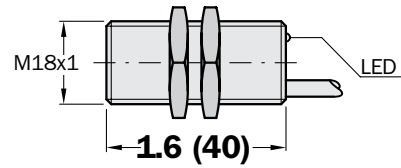
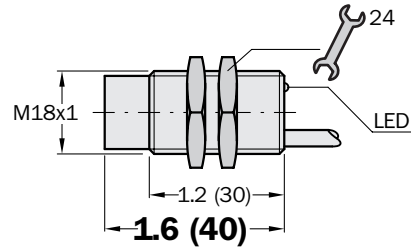

Accessories	page
Cables and connectors	909
Mounting brackets	925, 926

Electrical and Mechanical Data

Operating voltage U_b	10...30 V DC
Ripple U_{pp}	$\leq 10\%$ of U_b
Voltage drop U_b	≤ 1.5 V at I_a max.
Power consumption (without load)	≤ 10 mA
Continuous current I_a	≤ 300 mA
Time delay before availability t_v	≤ 10 ms
Hysteresis H	1% - 10% of s_r
Repeatability R (U_b and T_a constant)	$\leq 1\%$ of s_r
Temperature drift	$\pm 10\%$ of s_r
EMC	to EN 60 947-5-2
Wire-break protection	Yes
Short circuit protection (pulsed)	Yes
Reverse polarity protection	Yes
Power-up pulse suppression	Yes
Enclosure rating to DIN 40050	IP 67
Shock and vibration stress	30 g, 11 ms, 10 to 55 Hz, 1 mm
Ambient temperature T_a	-13...167°F (-25...75°C)
Housing material	Brass, nickel-plated, plastic
Tightening torque	25 Nm
Connection cable	PUR-PVC, 3 x 0.25 mm ²

Selection Table

Sensing range S_n in (mm)	Installation in metal	Switching output	Output function	Switching frequency f in Hz	Connection type	Type	Part no.
0.2 (5)		PNP		2000	Cable 2 m	IM18-05BPS-ZUK	1 017 430
0.2 (5)		NPN		2000	Cable 2 m	IM18-05BNS-ZUK	1 017 442
0.2 (5)		PNP		2000	Connector M12 x 1 mm	IM18-05BPS-ZCK	1 017 432
0.2 (5)		NPN		2000	Connector M12 x 1 mm	IM18-05BNS-ZCK	1 017 444
0.3 (8)		PNP		2000	Cable 2 m	IM18-08NPS-ZUK	1 017 431
0.3 (8)		NPN		2000	Cable 2 m	IM18-08NNS-ZUK	1 017 443
0.3 (8)		PNP		2000	Connector M12 x 1 mm	IM18-08NPS-ZCK	1 017 433
0.3 (8)		NPN		2000	Connector M12 x 1 mm	IM18-08NNS-ZCK	1 017 445

Connection Diagram

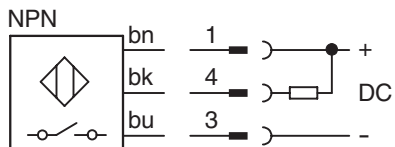
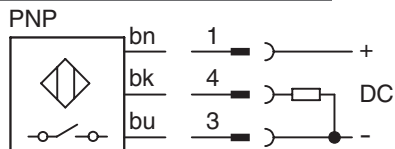

Wire color	Contact	Assignment
bn	brown	1 + V DC
bk	black	4 NO
bu	blue	3 - V DC

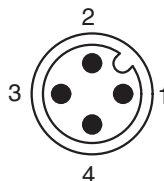

IM 18 2-wire

Inductive Proximity Sensors



Highlights

- Shielded or unshielded
- Normally open function
- Short circuit protection (pulsed)
- Robust brass housing, nickel-plated with fine thread M18 x 1 mm
- Cable or connector
- Enclosure rating IP 67
- LED status indicator

IM 18



Dimensional Drawing

dimensions in inches (mm)

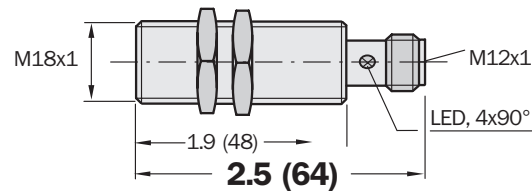
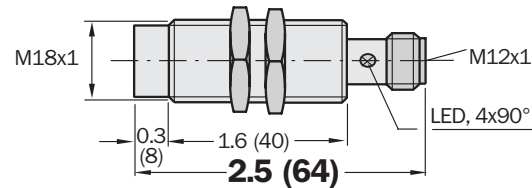
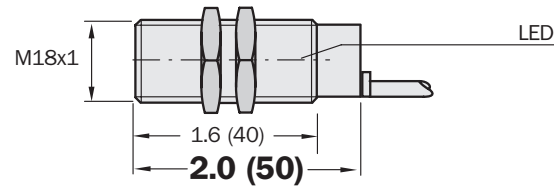
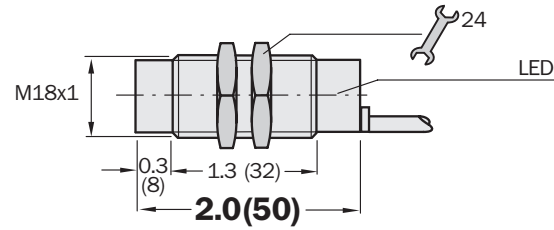

Accessories	page
Cables and connectors	909
Mounting brackets	925, 926

Electrical and Mechanical Data

Operating voltage U_b	10...30 V DC
Ripple U_{pp}	$\leq 10\%$
Voltage drop U_b	≤ 2.8 V at I_a max.
Load current	≥ 3 mA
Continuous current I_a	≤ 100 mA
Off-state current	≤ 0.8 mA
Time delay before availability t_v	≤ 50 ms
Hysteresis H	2% - 10% of s_r
Repeatability R (U_b and T_a constant)	$\leq 2\%$ of s_r
Temperature drift	$\pm 10\%$ of s_r
EMC	to EN 60 947-5-2
Short circuit protection (pulsed)	Yes
Reverse polarity protection	Yes
Enclosure rating to EN 60529	IP 67
Shock and vibration stress	30 g, 11 ms, 10 to 55 Hz, 1 mm
Ambient temperature T_a	-13...158°F (-25...70°C)
Housing material	Brass, nickel-plated, plastic
Tightening torque	30 Nm
Connection cable	PVC, 2 x 0.34 mm ²

Selection Table

Sensing range S_n in (mm)	Installation in metal	Output function	Switching frequency f in Hz	Connection type	Type	Part no.
0.2 (5)			300	Cable 2 m	IM18-05BDS-ZW1	6 020 318
0.2 (5)			300	Connector M12 x 1 mm	IM18-05BDS-ZC1	6 020 320
0.3 (8)			300	Cable 2 m	IM18-08NDS-ZW1	6 020 322
0.3 (8)			300	Connector M12 x 1 mm	IM18-08NDS-ZC1	6 020 324

Connection Diagram

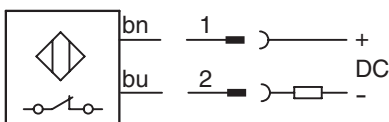
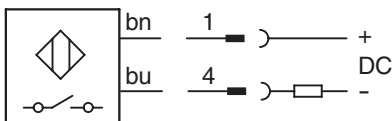

Wire color	Contact	Assignment
bn brown	1	+ V DC
bu blue	2/4	- V DC

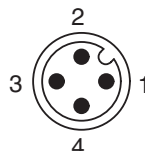

IM 18 Advanced

Inductive Proximity Sensors



Highlights

- Enhanced sensing range
- Short circuit protection (pulsed)
- Shielded or unshielded
- Robust brass housing, nickel-plated with fine thread M18 x 1 mm
- PNP or NPN output
- Cable and connector
- High switching frequency
- LED status indicator
- Normally open/normally closed function

IM 18 Advanced



Dimensional Drawing

dimensions in inches (mm)

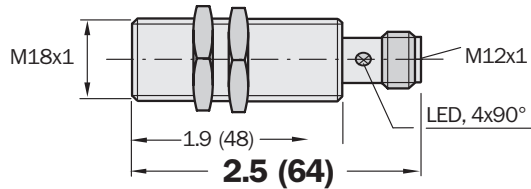
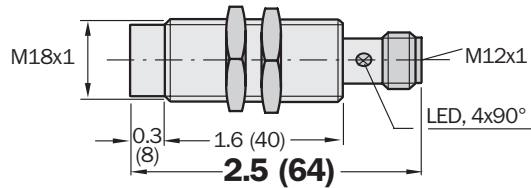
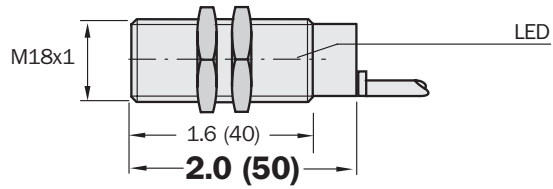
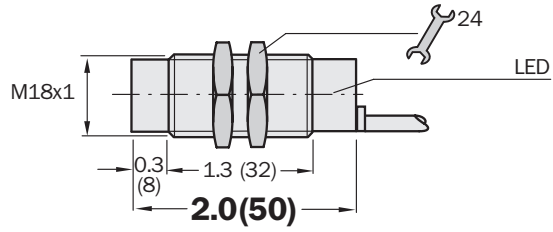

Accessories	page
Cables and connectors	909
Mounting brackets	925, 926

Electrical and Mechanical Data

Operating voltage U_b	10...30 V DC
Ripple U_{pp}	$\leq 10\%$ of U_b
Voltage drop U_b	≤ 1 V at I_a max.
Power consumption (without load)	≤ 10 mA
Continuous current I_a	≤ 400 mA
Time delay before availability t_v	≤ 100 ms
Hysteresis H	2% - 15% of s_r
Repeatability R (U_b and T_a constant)	$\leq 5\%$ of s_r
Temperature drift	$\pm 10\%$ of s_r
EMC	to EN 60 947-5-2
Wire-break protection	Yes
Short circuit protection (pulsed)	Yes
Reverse polarity protection	Yes
Power-up pulse suppression	Yes
Enclosure rating to DIN 40050	IP 67
Shock and vibration stress	30 g, 11 ms, 10 to 55 Hz, 1 mm
Ambient temperature T_a	-13...158°F (-25...70°C)
Housing material	Brass, nickel-plated, plastic
Tightening torque	30 Nm
Connection cable	PVC, 3 x 0.25 mm ²

Selection Table

Sensing range S_n in mm	Installation in metal	Switching output	Output function	Switching frequency f in Hz	Connection type	Type	Part no.
8		PNP		300	Cable 2 m	IM18-08BPS-ZW1	7 900 081
8		NPN		300	Cable 2 m	IM18-08BNS-ZW1	7 900 082
8		PNP		300	Cable 2 m	IM18-08BPO-ZW1	7 900 083
8		PNP		300	Connector M12 x 1 mm	IM18-08BPS-ZC1	7 900 085
8		NPN		300	Connector M12 x 1 mm	IM18-08BNS-ZC1	7 900 086
8		PNP		300	Connector M12 x 1 mm	IM18-08BPO-ZC1	7 900 087
12		PNP		300	Cable 2 m	IM18-12NPS-ZW1	7 900 093
12		NPN		300	Cable 2 m	IM18-12NNS-ZW1	7 900 094
12		PNP		300	Cable 2 m	IM18-12NPO-ZW1	7 900 095
12		PNP		300	Connector M12 x 1 mm	IM18-12NPS-ZC1	7 900 097
12		NPN		300	Connector M12 x 1 mm	IM18-12NNS-ZC1	7 900 098
12		PNP		300	Connector M12 x 1 mm	IM18-12NPO-ZC1	7 900 099

Connection Diagram

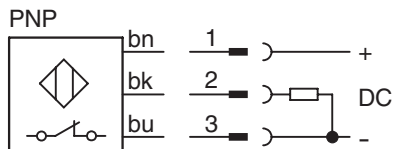
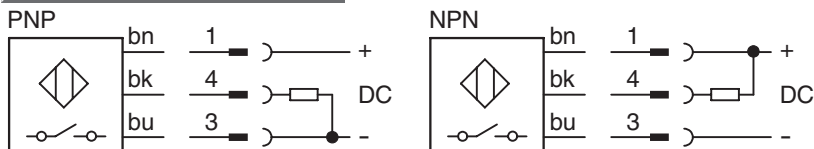

Wire color	Contact	Assignment
bn	brown	+ V DC
bk	black	NO/NC
bu	blue	- V DC

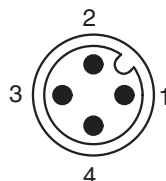

IM 18 Triple Sensing Range

Inductive Proximity Sensors



Highlights

- Triple sensing range
- Installation quasi flush or non-flush in metal
- Normally open function
- PNP or NPN output
- High switching frequency
- Short circuit protection (pulsed)
- Robust brass housing, nickel-plated with fine thread M8 x 1 mm
- Cable or connector
- Enclosure rating IP 67
- LED status indicator

IM 18 Triple Sensing Range



Dimensional Drawing

dimensions in inches (mm)

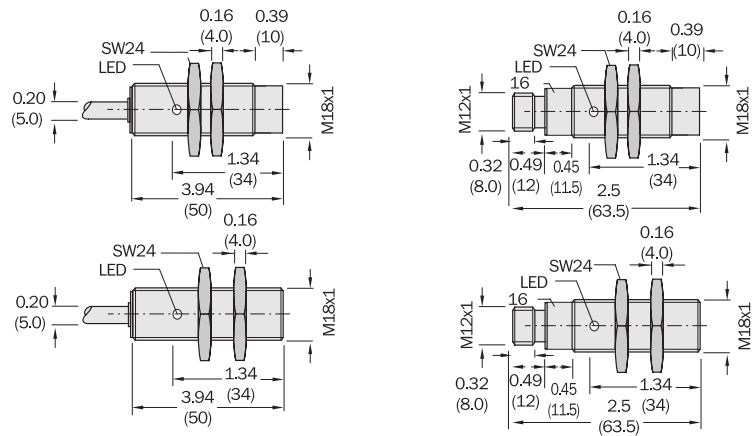

Accessories	page
Cables and connectors	909
Mounting brackets	925, 926

Electrical and Mechanical Data

Operating voltage U_b	10...30 V DC
Ripple U_{ss}	$\leq 20\%$ of U_b
Voltage drop U_d (at I_a max.)	≤ 2 V at I_a max.
Power consumption (without load)	≤ 10 mA
Continuous current I_a	≤ 200 mA
Time delay before availability T_v	≤ 100 ms
Hysteresis H	1% - 5% of s_r (5% typ.)
Repeatability R (U_b and T_a constant)	$\leq 5\%$ of s_r
Temperature drift	$\pm 10\%$ of s_r
EMC	to EN 60 947-5-2
Short circuit protection (pulsed)	Yes
Reverse polarity protection	Yes
Power-up pulse suppression	Yes
Enclosure rating to EN 60529	IP 67
Shock and vibration stress	30 g, 11 ms, 10 to 55 Hz, 1 mm
Ambient temperature T_a	-13...158°F (-25...70°C)
Housing material	Brass, chrome-plated, plastic
Tightening torque	30 Nm
Connection cable	PVC, 3 x 0.34 mm ²

Selection Table

Sensing range S_n in (mm)	Installation in metal	Switching output	Output function	Switching frequency f in Hz	Connection type	Type	Part no.
0.5 (12)		PNP		500	Cable 2 m	IM 18-12BPS-ZW1	6 027 515
0.5 (12)		NPN		500	Cable 2 m	IM18-12BNS-ZW1	6 027 516
0.5 (12)		PNP		500	Connector M12 x 1 mm	IM18-12BPS-ZC1	6 027 517
0.8 (20)		PNP		200	Cable 2 m	IM18-20NPS-ZW1	6 027 518
0.8 (20)		PNP		200	Connector M12 x 1 mm	IM18-20NPS-ZC1	6 027 519

* Installation notes "quasi flush"
 When mounting in conductible materials the sensors have to be installed with a distance A to the surface.
 A Steel, metal = 4 mm / A Stainless steel = 1.5 mm

Connection Diagram

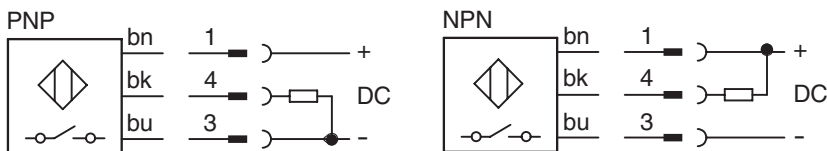

Wire color	Contact	Assignment
bn	brown	1 + V DC
bk	black	4 NO
bu	blue	3 - V DC

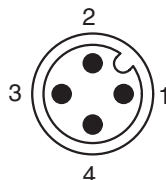

IM 18 Harsh Environment

Inductive Proximity Sensors



Highlights

- For harsh environment, resistant to most cutting oils
- Enclosure rating IP 68
- Shielded or unshielded
- PNP or NPN output
- Complementary output function
- Short circuit protection (pulsed)
- Robust brass housing, nickel-plated with fine thread M12 x 1 mm
- Internal enclosure housing in technopolymer
- LED status indicator (NO function)

IM 18 Harsh environment



Dimensional Drawing

dimensions in inches (mm)

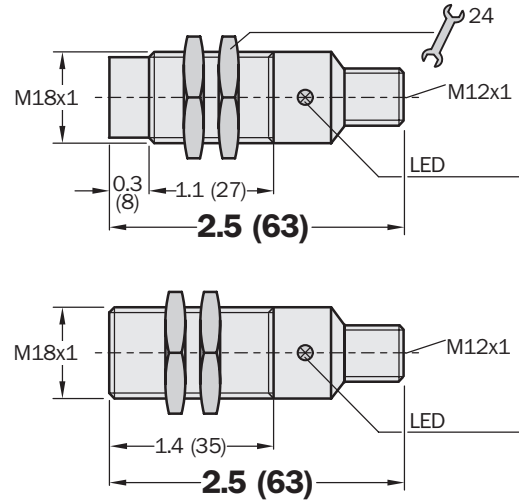

Accessories	page
Cables and connectors	909
Mounting brackets	925, 926

Electrical and Mechanical Data

Operating voltage U_b	10...30 V DC
Ripple U_{pp}	$\leq 10\%$
Voltage drop U_b	≤ 0.8 V at I_a max.
Power consumption (without load)	≤ 20 mA
Continuous current I_a	≤ 400 mA
Time delay before availability t_v	≤ 100 ms
Hysteresis H	2% - 10% of s_r
Repeatability R (U_b and T_a constant)	$\leq 5\%$ of s_r
Temperature drift	$\pm 10\%$ of s_r
EMC	to EN 60 947-5-2
Short circuit protection (pulsed)	Yes
Reverse polarity protection	Yes
Power-up pulse suppression	Yes
Enclosure rating	IP 68
Shock and vibration stress	30 g, 11 ms, 10 to 55 Hz, 1 mm
Ambient temperature T_a	-13...158°F (-25...70°C)
Housing material	Brass, nickel-plated, plastic
Tightening torque	40 Nm

Selection Table

Sensing range S_n in (mm)	Installation in metal	Switching output	Output function	Switching frequency f in Hz	Connection type	Type	Part no.
0.2 (5)		PNP	 complementary	1000	Connector M12 x 1 mm	IM18-05BPP-ZC1	7 902 931
0.2 (5)		NPN	 complementary	1000	Connector M12 x 1 mm	IM18-05BNP-ZC1	7 902 932
0.3 (8)		PNP	 complementary	1000	Connector M12 x 1 mm	IM18-08NPP-ZC1	7 902 933
0.3 (8)		NPN	 complementary	1000	Connector M12 x 1 mm	IM18-08NNP-ZC1	7 902 934

Connection Diagram

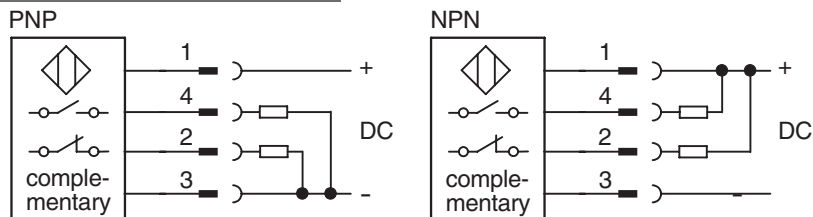

Wire color	Contact	Assignment
bn brown	1	+ V DC
wh white	2	NC
bu blue	3	- V DC
bk black	4	NO

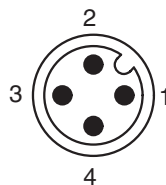

IM 18 QuadProx

Inductive Proximity Sensors



Highlights

- Programmable output functions in one sensor: PNP/NO, PNP/NC, NPN/NO, NPN/NC
- Robust brass housing, nickel-plated with fine thread M18 x 1 mm
- Shielded or unshielded
- Short circuit protection
- Cable or connector
- Enclosure rating IP 67
- LED status indicator (NO function)

IM 18 QuadProx



Dimensional Drawing

dimensions in inches (mm)

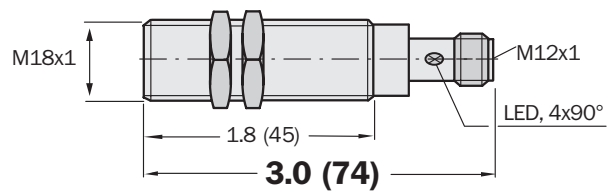
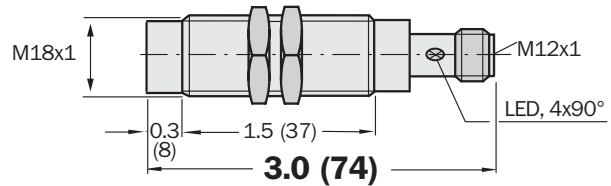
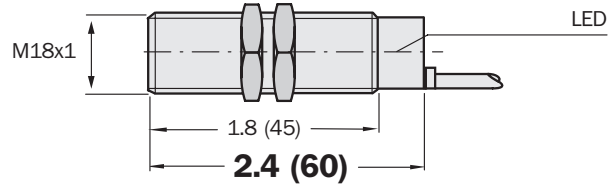
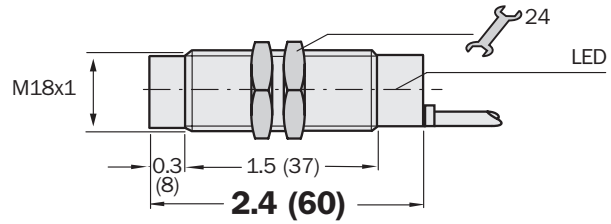

Accessories	page
Cables and connectors	909
Mounting brackets	925, 926

Electrical and Mechanical Data

Operating voltage U_b	10...30 V DC
Ripple U_{pp}	$\leq 10\%$
Voltage drop U_b	≤ 1.2 V at I_a max.
Power consumption (without load)	≤ 30 mA
Continuous current I_a	≤ 100 mA
Time delay before availability t_v	≤ 200 ms
Hysteresis H	2% - 10% of s_r
Repeatability R (U_b and T_a constant)	$\leq 5\%$ of s_r
Temperature drift	$\pm 10\%$ of s_r
EMC	to EN 60 947-5-2
Short circuit protection (pulsed)	Yes
Reverse polarity protection	Yes
Power-up pulse suppression	Yes
Enclosure rating	IP 67
Shock and vibration stress	30 g, 11 ms, 10 to 55 Hz, 1 mm
Ambient temperature T_a	-13...158°F (-25...70°C)
Housing material	Brass, nickel-plated, plastic
Tightening torque	40 Nm
Connection cable	PVC, 4 x 0.34 mm ²

Selection Table

Sensing range S_n in (mm)	Installation in metal	Switching output	Output function	Switching frequency f in Hz	Connection type	Type	Part no.
0.2 (5)		PNP/NPN config.		300	Cable 2 m	IM18-05BCP-ZW1	7 902 935
0.2 (5)		PNP/NPN config.		300	Connector M12 x 1 mm	IM18-05BCP-ZC1	7 902 936
0.3 (8)		PNP/NPN config.		300	Cable 2 m	IM18-08NCP-ZW1	7 902 937
0.3 (8)		PNP/NPN config.		300	Connector M12 x 1 mm	IM18-08NCP-ZC1	7 902 938

Connection Diagram

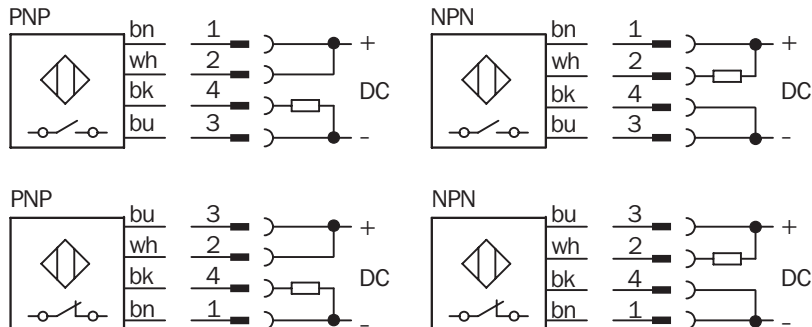

Wire color		Contact	Configurable output function			
			PNP		NPN	
bn	brown	1	+V DC	-V DC	+V DC	-V DC
wh	white	2	+V DC	+V DC	NO	NC
bu	blue	3	-V DC	+V DC	-V DC	+V DC
bk	black	4	NO	NC	-V DC	-V DC

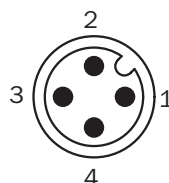

IM 18 Universal

Inductive Proximity Sensors



Highlights

- Shielded or unshielded
- Robust brass housing, nickel-plated with fine thread M18 x 1 mm
- Broad operating voltage range in AC and DC
- Enclosure rating IP 67
- Normally open/normally closed function
- LED status indicator
- High switching frequency

IM 18 Universal



Dimensional Drawing

dimensions in inches (mm)

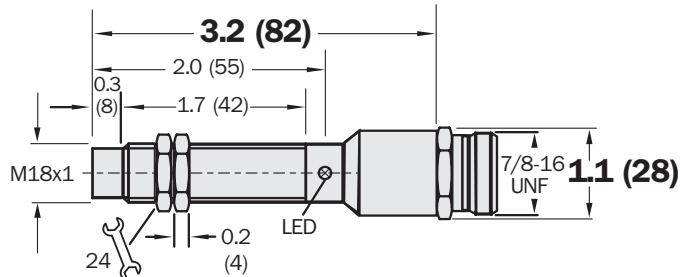
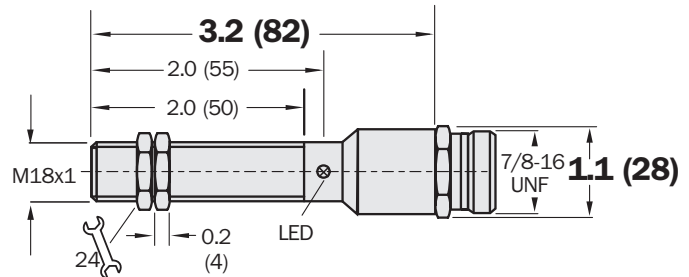
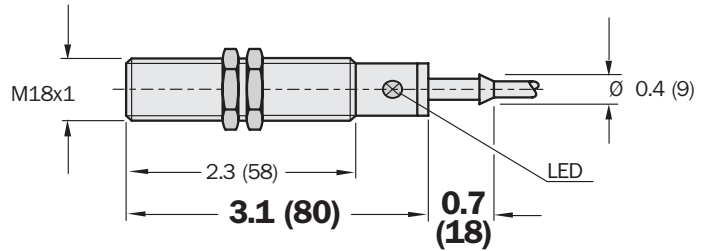
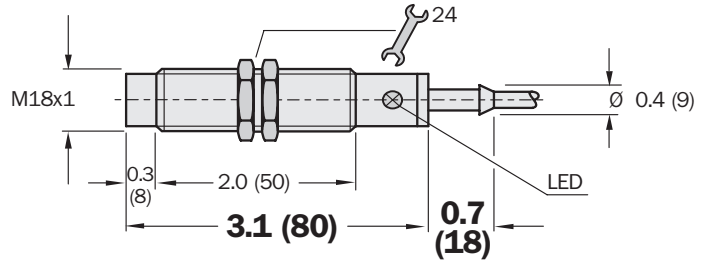

Accessories	page
Cables and connectors	911
Mounting brackets	925, 926

Electrical and Mechanical Data

Operating voltage U_b	20...250 V AC / DC
Voltage drop U_b	≤ 6.5 V AC / ≤ 6 V DC at I_a max.
Continuous current I_a	≤ 350 mA AC (...+50°C), ≤ 250 mA AC (...+80°C), ≤ 100 mA DC
Peak current I_k	2.2 A (20ms/0.5 Hz)
Min. load current	5 mA
Residual current	≤ 2.5 mA (250 V AC), ≤ 1.3 mA (110 V AC), ≤ 0.8 mA (24 V DC)
Time delay before availability t_v	approx. 8 ms
Hysteresis H	1% - 15% of s_r
Repeatability R (U_b and T_a constant)	$\leq 10\%$ of s_r
Temperature drift	$\pm 10\%$ of s_r
EMC	to EN 60 947-5-2
Wire-break protection	-
Short circuit protection (pulsed)	-
Reverse polarity protection	-
Power-up pulse suppression	Yes
Enclosure rating to DIN 40050	IP 67
Protection class	
Shock and vibration stress	30 g, 11 ms, 10 to 55 Hz, 1 mm
Ambient temperature T_a	13...176°F (-25...80°C)
Housing material	Brass, nickel-plated, plastic
Tightening torque	35 Nm
Connection cable	PUR-PVC, 2 x 0.5 mm ²

Selection Table

Sensing range S_n in (mm)	Installation in metal	Output function	Switching frequency f in Hz	Connection type	Type	Part no.
0.2 (5)			25 (AC) / 100 (DC)	Cable 2 m	IM18-05BUS-ZU0	7 902 122
0.2 (5)			25 (AC) / 100 (DC)	Cable 2 m	IM18-05BU0-ZU0	7 902 123
0.2 (5)			25 (AC) / 100 (DC)	Connector 3-pin Mini	IM18-05BUS-ZM0	6 021 223
0.3 (8)			25 (AC) / 100 (DC)	Cable 2 m	IM18-08NUS-ZU0	7 902 124
0.3 (8)			25 (AC) / 100 (DC)	Cable 2 m	IM18-08NU0-ZU0	7 902 125
0.3 (8)			25 (AC) / 100 (DC)	Connector 3-pin Mini	IM18-08NUS-ZM0	6 021 224

Connection Diagram

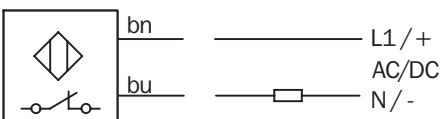
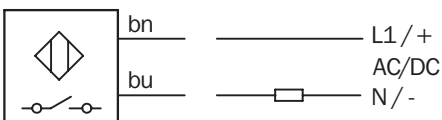

Wire color	Assignment
bn	brown L1 / +
bu	blue N / -

3-Pin Mini Connector

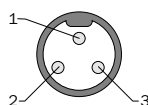

IM 18 NAMUR

Inductive Proximity Sensors



Highlights

- NAMUR to DIN 19 234
- Enclosure rating IP 67
- Shielded or unshielded
- LED status indicator (NO function)
- Robust brass housing, nickel-plated with fine thread M18 x 1 mm
- High switching frequency

IM 18 NAMUR

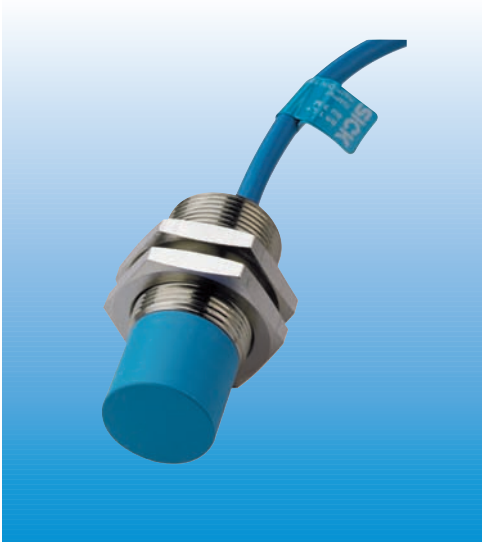

Dimensional Drawing

dimensions in inches (mm)

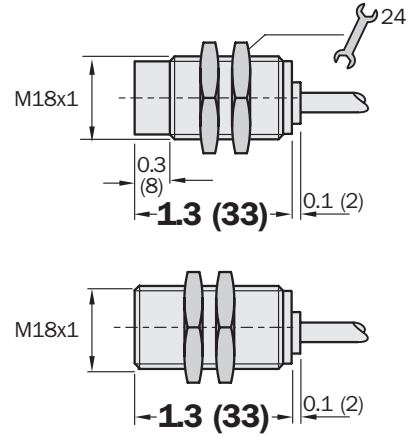

Accessories	page
Mounting brackets	925, 926
Power supply	966

Electrical and Mechanical Data

Operating voltage U_b	5...25 V DC
Nominal voltage U_n	8.2 V DC
Power consumption, attenuated	≤ 1.0 mA
Power consumption, unattenuated	≥ 2.2 mA
Internal capacitance	≤ 230 nF (flush) ≤ 240 nF (non-flush)
Internal inductance	≤ 60 μ H
Cable resistance	≤ 50 Ω
Temperature drift	$\pm 10\%$ of s_r
EMC	to EN 60 947-5-2
Short-circuit protected	Yes
Reverse polarity protected	Yes
Enclosure rating to EN 60529	IP 67
Shock and vibration stress	30 g, 11 ms, 10 to 55 Hz, 1 mm
Ambient temperature T_a	-13...158°F (-25...70°C)
Housing material	Brass, nickel-plated, plastic
Tightening torque	35 Nm
Connection cable	PVC, 2 x 0.34 mm ² , blue
Max. data for connecting isolating unit EN 2 EX or other approved isolating amplifier:	
Short circuit current I_k max	50 mA
No load voltage U_o	15 V
Power loss P_{max}	180 mW

Selection Table

Sensing range S_n in (mm)	Installation in metal	Switching output	Output function	Switching frequency f in Hz	Connection type	Type	Part no.
0.2 (5)		NAMUR		720	Cable 2 m	IM18-05B-N-ZW0	6 021 126
0.3 (8)		NAMUR		300	Cable 2 m	IM18-08N-N-ZW0	6 021 127

Connection Diagram



Wire color			Assignment
bn	braun	brown	+ V DC
bu	blau	blue	- V DC

IM 30 Standard

Inductive Proximity Sensors



Highlights

- Shielded or unshielded
- PNP or NPN output
- Normally open/normally closed function
- High switching frequency
- Short circuit protection (pulsed)
- Robust brass housing, nickel-plated with fine thread M30 x 1.5 mm
- Cable or connector
- Enclosure rating IP 67
- LED status indicator

IM 30 Standard



Dimensional Drawing

dimensions in inches (mm)

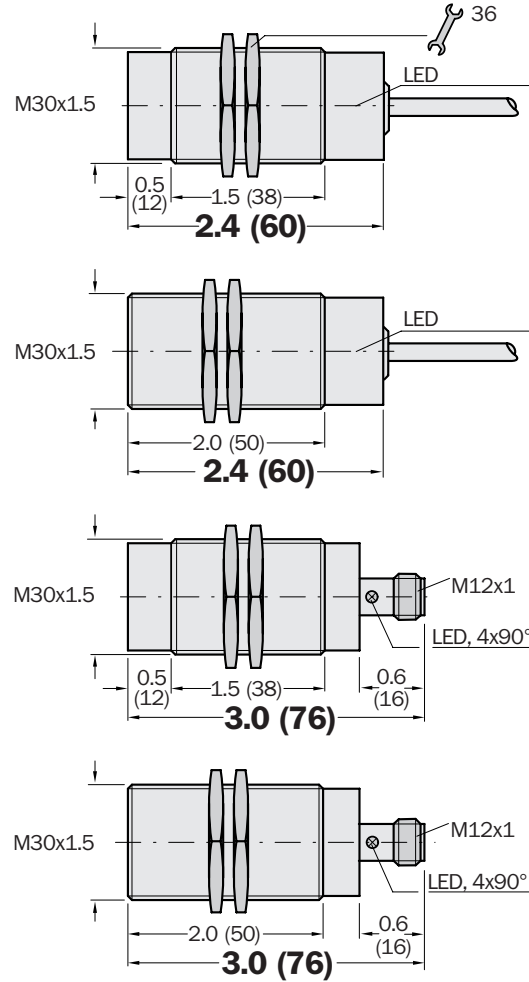

Accessories	page
Cables and connectors	909
Mounting brackets	927

Electrical and Mechanical Data

Operating voltage U_b	10...30 V DC
Ripple U_{pp}	$\leq 10\%$
Voltage drop U_b	≤ 1 V at I_a max.
Power consumption (without load)	≤ 20 mA
Continuous current I_a	≤ 400 mA
Time delay before availability t_v	≤ 100 ms
Hysteresis H typ.	2% - 10% of s_r
Repeatability R (U_b and T_a constant)	$\leq 2\%$ of s_r
Temperature drift	$\pm 10\%$ of s_r
EMC	to EN 60 947-5-2
Short circuit protection (pulsed)	Yes
Reverse polarity protection	Yes
Power-up pulse suppression	Yes
Enclosure rating to DIN 40050	IP 67
Shock and vibration stress	30 g, 11 ms, 10 to 55 Hz, 1 mm
Ambient temperature T_a	-13...167°F (-25...75°C)
Housing material	Brass, nickel-plated, plastic
Tightening torque	60 Nm
Connection cable	PUR-PVC, 3 x 0.5 mm ²

Selection Table

Sensing range S_n in (mm)	Installation in metal	Switching output	Output function	Switching frequency f in Hz	Connection type	Type	Part no.
0.4 (10)		PNP		200	Cable 2 m	IM30-10BPS-ZW1	6 020 274
0.4 (10)		NPN		200	Cable 2 m	IM30-10BNS-ZW1	6 020 275
0.4 (10)		PNP		200	Connector M12 x 1 mm	IM30-10BPS-ZC1	6 020 278
0.4 (10)		NPN		200	Connector M12 x 1 mm	IM30-10BNS-ZC1	6 020 279
0.4 (10)		PNP		200	Connector M12 x 1 mm	IM30-10BPO-ZC1	6 020 280
0.6 (15)		PNP		200	Cable 2 m	IM30-15NPS-ZW1	6 020 282
0.6 (15)		NPN		200	Cable 2 m	IM30-15NNS-ZW1	6 020 283
0.6 (15)		PNP		200	Cable 2 m	IM30-15NPO-ZW1	6 020 284
0.6 (15)		PNP		200	Connector M12 x 1 mm	IM30-15NPS-ZC1	6 020 286
0.6 (15)		NPN		200	Connector M12 x 1 mm	IM30-15NNS-ZC1	6 020 287

Connection Diagram

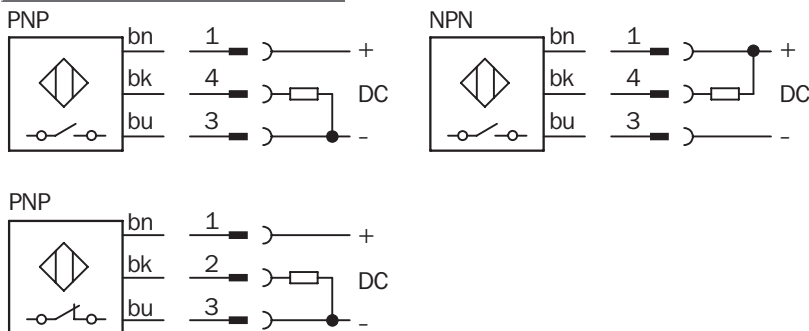

Wire color	Contact	Assignment
bn	brown	1 + V DC
bk	black	2/4 NO/NC
bu	blue	3 - V DC

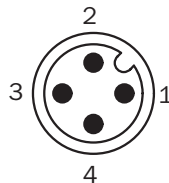

IM 30 Short

Inductive Proximity Sensors



Highlights

- Shielded or unshielded
- PNP or NPN output
- Normally open function
- Short circuit protection (pulsed)
- Robust brass housing, nickel-plated with fine thread M30 x 1.5 mm
- Cable or connector
- Enclosure rating IP 67
- LED status indicator

IM 30 Short



Dimensional Drawing

dimensions in inches (mm)

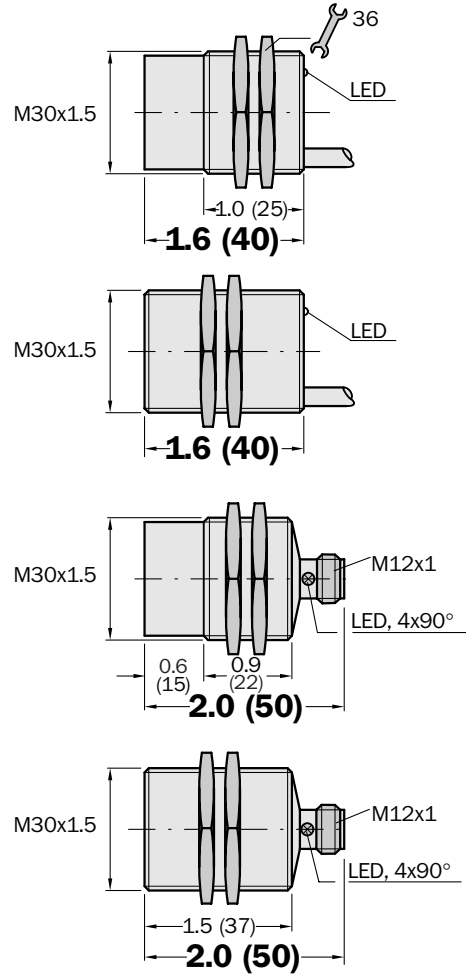

Accessories	page
Cables and connectors	909
Mounting brackets	927

Electrical and Mechanical Data

Operating voltage U_b	10...30 V DC
Ripple U_{pp}	$\leq 10\%$ of U_b
Voltage drop U_b	≤ 1.5 V at I_a max.
Power consumption (without load)	≤ 10 mA
Continuous current I_a	≤ 300 mA
Time delay before availability t_v	≤ 10 ms
Hysteresis H	1% - 10% of s_r
Repeatability R (U_b and T_a constant)	$\leq 1\%$ of s_r
Temperature drift	$\pm 10\%$ of s_r
EMC	to EN 60 947-5-2
Wire-break protection	Yes
Short circuit protection (pulsed)	Yes
Reverse polarity protection	Yes
Power-up pulse suppression	Yes
Enclosure rating to DIN 40050	IP 67
Shock and vibration stress	30 g, 11 ms, 10 to 55 Hz, 1 mm
Ambient temperature T_a	-13...167°F (-25...75°C)
Housing material	Brass, nickel-plated, plastic
Tightening torque	50 Nm
Connection cable	PUR-PVC, 3 x 0.5 mm ²

Selection Table

Sensing range S_n in (mm)	Installation in metal	Switching output	Output function	Switching frequency f in Hz	Connection type	Type	Part no.
0.4 (10)		PNP		500	Cable 2 m	IM30-10BPS-ZUK	1 017434
0.4 (10)		NPN		500	Cable 2 m	IM30-10BNS-ZUK	1 017 446
0.4 (10)		PNP		500	Connector M12 x 1 mm	IM30-10BPS-ZCK	1 017 436
0.6 (15)		PNP		500	Cable 2 m	IM30-15NPS-ZUK	1 017 435
0.6 (15)		NPN		500	Cable 2 m	IM30-15NNS-ZUK	1 017 447
0.6 (15)		PNP		500	Connector M12 x 1 mm	IM30-15NPS-ZCK	1 017 437

Connection Diagram

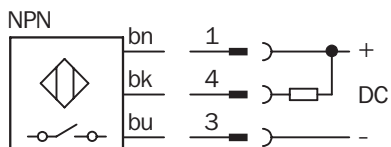
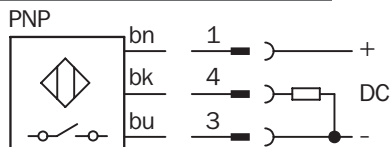

Wire color	Contact	Assignment
bn	brown	1 + V DC
bk	black	4 NO
bu	blue	3 - V DC

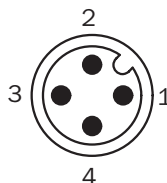

IM 30 2-wire

Inductive Proximity Sensors



Highlights

- Shielded or unshielded
- Normally open/normally closed function
- High switching frequency
- Short circuit protection (pulsed)
- Robust brass housing, nickel-plating with fine thread M30 x 1.5 mm
- Cable or connector
- Enclosure rating IP 67
- LED status indicator

IM 30 2-wire



Dimensional Drawing

dimensions in inches (mm)

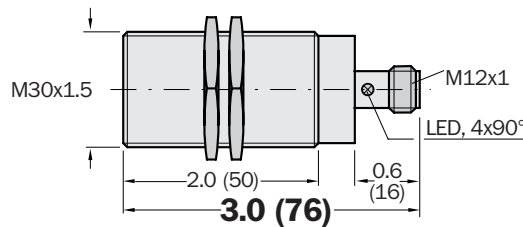
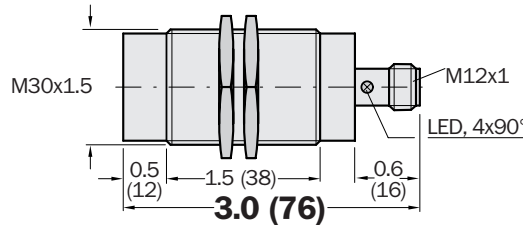
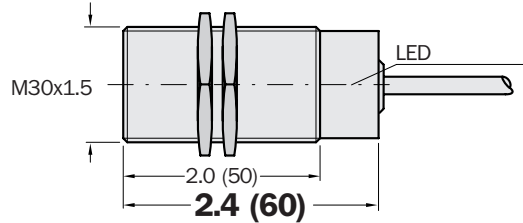
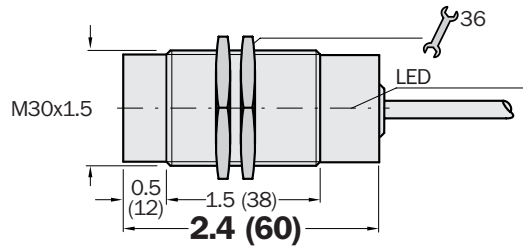

Accessories	page
Cables and connectors	909
Mounting brackets	927

Electrical and Mechanical Data

Operating voltage U_b	10...30 V DC
Ripple U_{pp}	$\leq 10\%$
Voltage drop U_b	≤ 2.8 V at I_a max.
Load current	≥ 3 mA
Continuous current I_a	≤ 100 mA
OFF state current	≤ 0.8 mA
Time delay before availability t_v	≤ 50 ms
Hysteresis H	2% - 10% of s_r
Repeatability R (U_b and T_a constant)	$\leq 2\%$ of s_r
Temperature drift	$\pm 10\%$ of s_r
EMC	to EN 60 947-5-2
Short circuit protection (pulsed)	Yes
Reverse polarity protection	Yes
Power-up pulse suppression	Yes
Enclosure rating to EN 40050	IP 67
Shock and vibration stress	30 g, 11 ms, 10 bis 55 Hz, 1 mm
Ambient temperature T_a	-13...158°F (-25...70°C)
Housing material	Brass nickel-plated, plastic
Tightening torque	30 Nm
Connection cable	PVC, 2 x 0.5 mm ²

Selection Table

Sensing range S_n in (mm)	Installation in metal	Output function	Switching frequency f in Hz	Connection	Type	Part no.
0.4 (10)			200	Cable 2 m	IM30-10BDS-ZW1	6 020 326
0.4 (10)			200	Connector M12 x 1 mm	IM30-10BDS-ZC1	6 020 328
0.6 (15)			200	Cable 2 m	IM30-15NDS-ZW1	6 020 330
0.6 (15)			200	Connector M12 x 1 mm	IM30-15NDS-ZC1	6 020 332

Connection Diagram

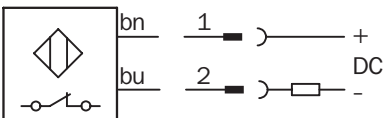
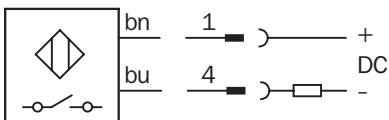

Wire color	Contact	Assignment
bn brown	1	+ V DC
bu blue	2/4	- V DC

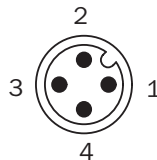

IM 30 Advanced

Inductive Proximity Sensors



IM 30 Advanced



Highlights

- Enhanced sensing range
- Shielded or unshielded
- PNP or NPN output
- Normally open/normally closed function
- High switching frequency
- Short circuit protection (pulsed)
- Robust brass housing, nickel-plated with fine thread M30 x 1.5 mm
- Cable or connector
- Enclosure rating IP 67
- LED status indicator

Dimensional Drawing

dimensions in inches (mm)

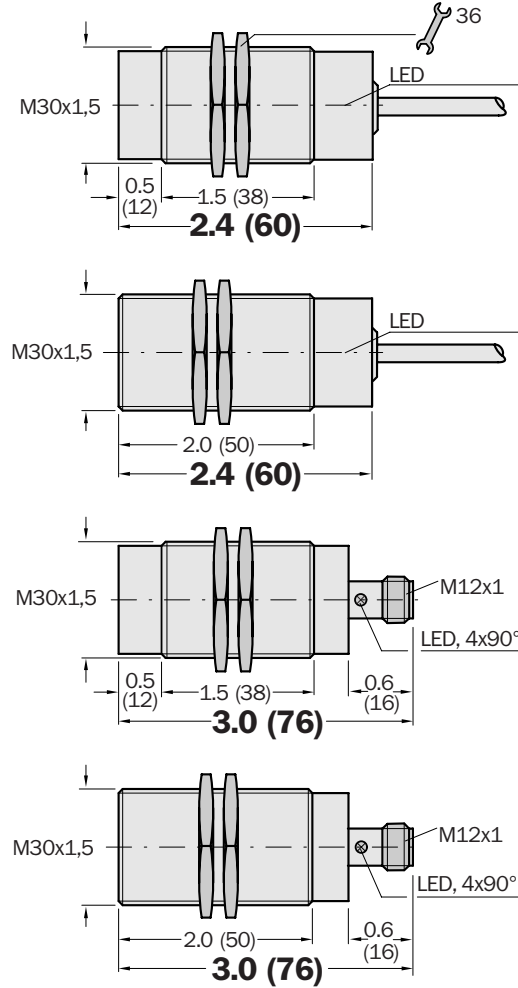

Accessories	page
Cables and connectors	909
Mounting brackets	927

Electrical and Mechanical Data

Operating voltage U_b	10...30 V DC
Ripple U_{pp}	$\leq 10\%$ of U_b
Voltage drop U_b	≤ 1 V at I_a max.
Power consumption (without load)	≤ 10 mA
Continuous current I_a	≤ 400 mA
Time delay before availability t_v	≤ 100 ms
Hysteresis H	2% - 15% of s_r
Repeatability R (U_b and T_a constant)	$\leq 5\%$ of s_r
Temperature drift	$\pm 10\%$ of s_r
EMC	to EN 60 947-5-2
Wire-break protection	Yes
Short circuit protection (pulsed)	Yes
Reverse polarity protection	Yes
Power-up pulse suppression	Yes
Enclosure rating to DIN 40050	IP 67
Shock and vibration stress	30 g, 11 ms, 10 to 55 Hz, 1 mm
Ambient temperature T_a	-13...167°F (-25...75°C)
Housing material	Brass, nickel-plated, plastic
Tightening torque	60 Nm
Connection cable	PVC, 3 x 0.5 mm ²

Selection Table

Sensing range S_n in (mm)	Installation in metal	Switching output	Output function	Switching frequency f in Hz	Connection type	Type	Part no.
0.6 (15)		PNP		150	Cable 2 m	IM30-15BPS-ZW1	7 900 141
0.6 (15)		NPN		150	Cable 2 m	IM30-15BNS-ZW1	7 900 142
0.6 (15)		PNP		150	Cable 2 m	IM30-15BPO-ZW1	7 900 143
0.6 (15)		PNP		150	Connector M12 x 1 mm	IM30-15BPS-ZC1	7 900 145
0.6 (15)		NPN		150	Connector M12 x 1 mm	IM30-15BNS-ZC1	7 900 146
0.6 (15)		PNP		150	Connector M12 x 1 mm	IM30-15BPO-ZC1	7 900 147
0.8 (20)		PNP		150	Cable 2 m	IM30-20NPS-ZW1	7 900 153
0.8 (20)		NPN		150	Cable 2 m	IM30-20NNS-ZW1	7 900 154
0.8 (20)		PNP		150	Cable 2 m	IM30-20NPO-ZW1	7 900 155
0.8 (20)		PNP		150	Connector M12 x 1 mm	IM30-20NPS-ZC1	7 900 157
0.8 (20)		NPN		150	Connector M12 x 1 mm	IM30-20NNS-ZC1	7 900158
0.8 (20)		PNP		150	Connector M12 x 1 mm	IM30-20NPO-ZC1	7 900 159

Connection Diagram

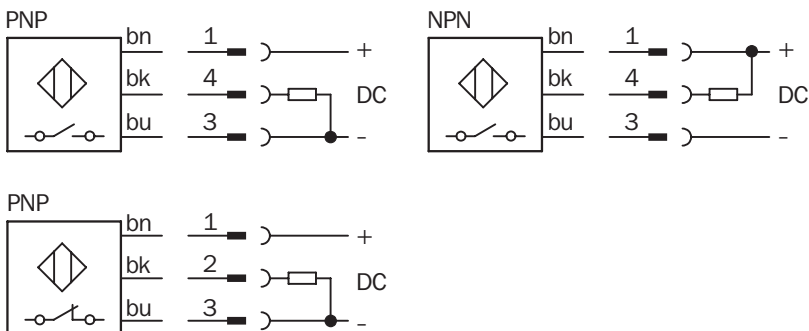

Wire color	Contact	Assignment
bn	brown	1 + V DC
bk	black	2/4 NO/NC
bu	blue	3 - V DC

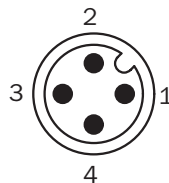

IM 30 Triple Sensing Range

Inductive Proximity Sensors



Highlights

- Triple sensing range
- Installation quasi flush or non-flush in metal
- Normally open function
- PNP or NPN output
- High switching frequency
- Short circuit protection (pulsed)
- Robust brass housing, nickel-plated with fine thread M8 x 1 mm
- Cable or connector
- Enclosure rating IP 67
- LED status indicator

IM 30 Triple Sensing Range

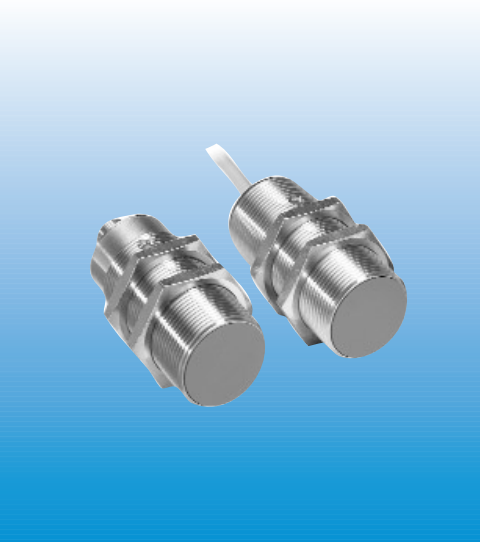

Dimensional Drawing

dimensions in inches (mm)

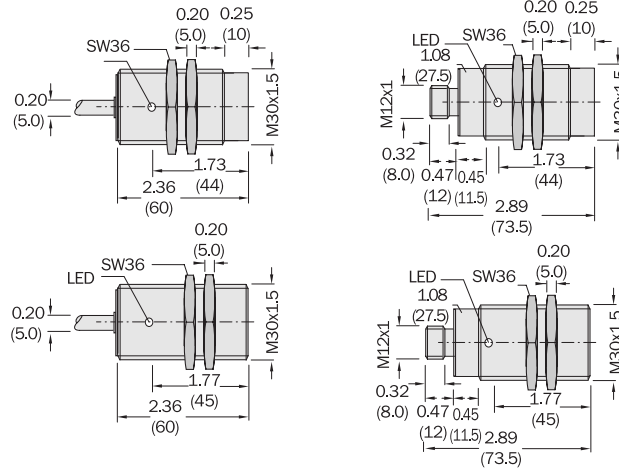

Accessories	page
Cables and connectors	909
Mounting brackets	927

Electrical and Mechanical Data

Operating voltage U_b	10...30 V DC
Ripple U_{ss}	$\leq 20\%$ of U_b
Voltage drop U_d (at I_a max.)	≤ 2 V at I_a max.
Power consumption (without load)	≤ 10 mA
Continuous current I_a	≤ 200 mA
Time delay before availability T_v	≤ 100 ms
Hysteresis H	1% - 5% of s_r (5% typ.)
Repeatability R (U_b and T_a constant)	$\leq 5\%$ of s_r
Temperature drift	$\pm 10\%$ of s_r
EMC	to EN 60 947-5-2
Short circuit protection (pulsed)	Yes
Reverse polarity protection	Yes
Power-up pulse suppression	Yes
Enclosure rating to EN 60529	IP 67
Shock and vibration stress	30 g, 11 ms, 10 to 55 Hz, 1 mm
Ambient temperature T_a	-13...158°F (-25...70°C)
Housing material	Brass, chrome-plated, plastic
Tightening torque	60 Nm
Connection cable	PVC, 3 x 0.34 mm ²

Selection Table

Sensing range S_n in (mm)	Installation in metal	Switching output	Output function	Switching frequency f in Hz	Connection type	Type	Part no.
0.9 (22)	*	NPN		200	Cable 2 m	IM 30-22BNS-ZW1	6 027 520
0.9 (22)	*	PNP		200	Connector M12 x 1 mm	IM30-22BPS-ZC1	6 027 521
1.6 (40)		PNP		100	Connector M12 x 1 mm	IM30-40NPS-ZC1	6 027 522

* Installation notes "quasi flush"

When mounting in conductible materials the sensors have to be installed with a distance A to the surface.

A Steel, metal = 6 mm / A Stainless steel = 2 mm

Connection Diagram

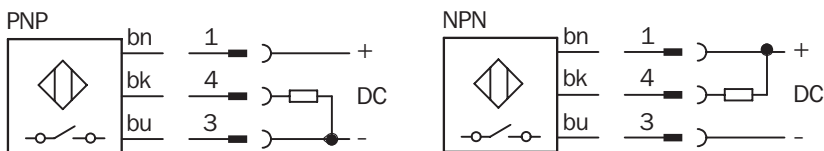

Wire color	Contact	Assignment
bn	brown	1 + V DC
bk	black	4 NO
bu	blue	3 - V DC

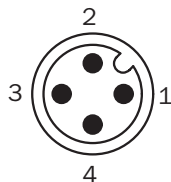

IM 30 Universal

Inductive Proximity Sensors



Highlights

- Shielded or unshielded
- Broad operating voltage range in AC and DC
- Normally open/normally closed function
- Robust brass housing, nickel-plated with fine thread M30 x 1.5 mm
- Enclosure rating IP 67
- LED status indicator

IM 30 Universal



Dimensional Drawing

dimensions in inches (mm)

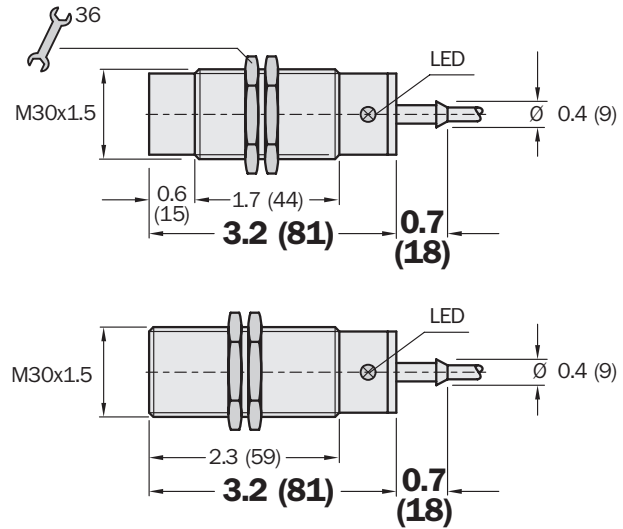







Accessories	page
Mounting brackets	927

Electrical and Mechanical Data

Operating voltage U_b	2...250 V AC / DC
Voltage drop U_b	≤ 6.5 V AC / ≤ 6 V DC at I_a max.
Continuous current I_a	≤ 350 mA AC (...+50°C), ≤ 250 mA AC (...+80°C), ≤ 100 mA DC
Peak current I_k	2.2 A (20ms/0.5 Hz)
Min. load current	5 mA
Residual current	≤ 2.5 mA (250 V AC), ≤ 1.3 mA (110 V AC), ≤ 0.8 mA (24 V DC)
Time delay before availability t_v	approx. 8 ms
Hysteresis H	1% - 15% of s_r
Repeatability R (U_b and T_a constant)	$\leq 10\%$ of s_r
Temperature drift	$\pm 10\%$ of s_r
EMC	to EN 60 947-5-2
Wire-break protection	-
Short circuit protection (pulsed)	-
Reverse polarity protection	-
Power-up pulse suppression	Yes
Enclosure rating to DIN 40050	IP 67
Protection class	
Shock and vibration stress	30 g, 11 ms, 10 to 55 Hz, 1 mm
Ambient temperature T_a	13...176°F (-25...80°C)
Housing material	Brass, nickel-plated, plastic
Tightening torque	50 Nm
Connection cable	PUR-PVC, 2 x 0.5 mm ²

Selection Table

Sensing range S_n in (mm)	Installation in metal	Output function	Switching frequency f in Hz	Connection	Type	Part no.
0.4 (10)			25 (AC) / 30 (DC)	Cable 2 m	IM30-10BUS-ZU0	7 902 126
0.4 (10)			25 (AC) / 30 (DC)	Cable 2 m	IM30-10BU0-ZU0	7 902 127
0.6 (15)			25 (AC) / 30 (DC)	Cable 2 m	IM30-15NUS-ZU0	7 902 128

Connection Diagram

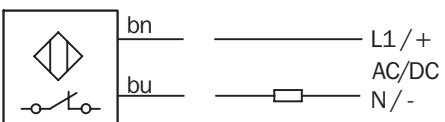
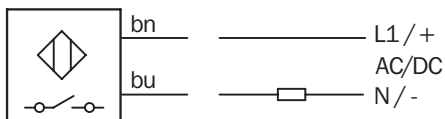

Wire color	Assignment
bn	brown L1 / +
bu	blue N / -

IM 30 NAMUR

Inductive Proximity Sensors



Highlights

- Shielded
- High switching frequency
- Short circuit protection (pulsed)
- Solid stainless steel housing
- Cable
- Enclosure rating IP 67
- LED status indicator

IM 30 NAMUR



Dimensional Drawing

dimensions in inches (mm)

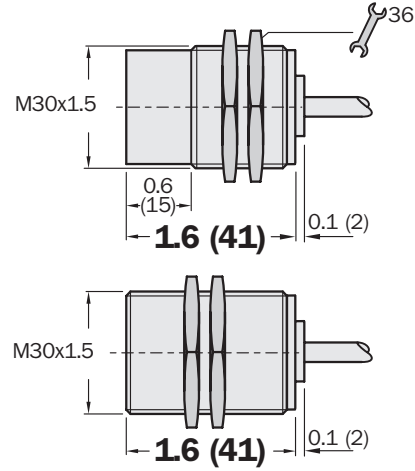

Accessories	page
Mounting brackets	927
Power supply	966

Electrical and Mechanical Data

Operating voltage U_b	5...25 V DC
Rated voltage U_n	8.2 V DC
Power consumption, attenuated	≤ 1.0 mA
Power Consumption, unattenuated	≥ 2.2 mA
Internal capacitance	≤ 230 nF (flush) ≤ 240 nF (non-flush)
Internal inductance	≤ 130 μ H (flush) ≤ 100 μ H (non-flush)
Cable resistance	≤ 50 Ω
Time delay before availability t_v	≤ 2 ms
Hysteresis H	1% - 10% of s_r
Repeatability R (U_b and T_a constant)	10% of s_r
Temperature drift	$\pm 10\%$ of s_r
EMC	to EN 60 947-5-2
Short circuit protected	Yes
Reverse polarity protected	Yes
Enclosure rating to DIN 40050	IP 67
Shock and vibration stress	30 g, 11 ms, 10 to 55 Hz, 1 mm
Ambient temperature T_a	-13...158°F (-25...70°C)
Housing material	Brass, nickel-plated, plastic
Tightening torque	50 Nm
Connection cable	PUR-PVC, 3 x 0.055 mm ² , blue
Max. data for connecting isolating unit EN 2 EX or other approved isolating amplifier:	
Short circuit current I_k max	50 mA
No load voltage U_o	15 V
Power loss P_{max}	180 mW

Selection Table

Sensing range S_n in (mm)	Installation in metal	Switching output	Output function	Switching frequency f in Hz	Connection type	Type	Part no.
0.4 (10)		NAMUR		450	Cable 2 m	IM30-10B-N-ZW0	6 021 128
0.6 (15)		NAMUR		200	Cable 2 m	IM30-15N-N-ZW0	6 021 129

Connection Diagram

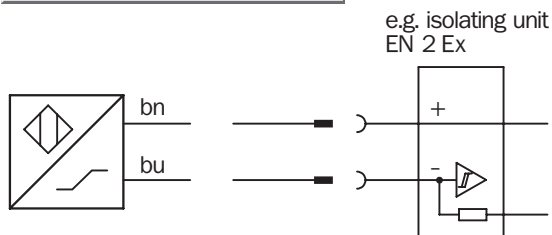

Wire color			Assignment
bn	braun	brown	+ V DC
bu	blau	blue	- V DC

IH 03 Miniature

Inductive Proximity Sensors



Highlights

- Shielded
- PNP or NPN output
- Normally open function
- High switching frequency
- Short circuit protection (pulsed)
- Solid stainless steel housing
- Cable
- Enclosure rating IP 67
- LED status indicator

IH 03 Miniature

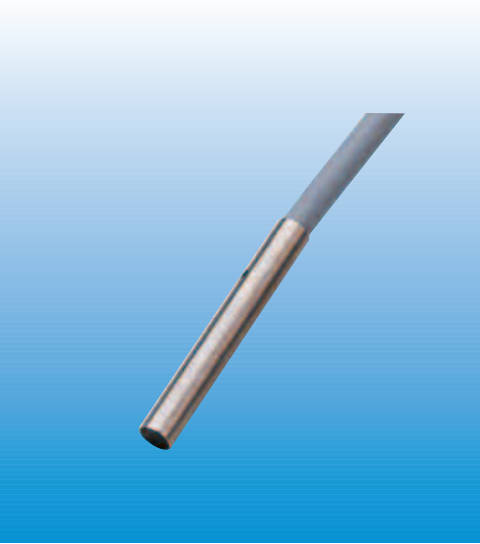

Dimensional Drawing

dimensions in inches (mm)

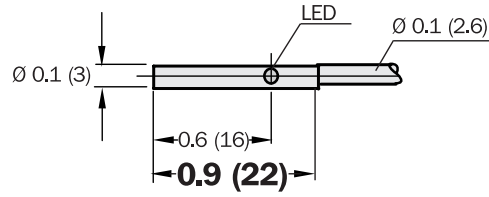

Electrical and Mechanical Data

Operating voltage U_b	10...30 V DC
Ripple U_{pp}	$\leq 20\%$ of U_b
Voltage drop U_b	≤ 0.6 V max. at I_a max.
Power consumption (without load)	10 mA
Continuous current I_a	≤ 100 mA
Time delay before availability t_v	≤ 10 ms
Hysteresis H	10% of s_r
Repeatability R (U_b and T_a constant)	$\leq 2\%$
Temperature drift	$\pm 10\%$ of s_r
EMC	to EN 60 947-5-2
Short circuit protection (pulsed)	Yes
Reverse polarity protection	Yes
Power-up pulse suppression	Yes
Enclosure rating to DIN 40050	IP 67
Shock and vibration stress	30 g, 11 ms, 10 to 55 Hz, 1 mm
Ambient temperature T_a	-13...158°F (-25...70°C)
Housing material	Stainless steel, plastic
Connection cable	PUR-PVC, 3 x 0.055 mm ²

Selection Table

Sensing range S_n in (mm)	Installation in metal	Switching output	Output function	Switching frequency f in Hz	Connection type	Type	Part no.
0.02 (0.6)		PNP		2000	Cable 2 m	IH03-0B6PS-VU1	6 020 141
0.02 (0.6)		NPN		2000	Cable 2 m	IH03-0B6NS-VU1	6 020 142
0.02 (0.6)		PNP		2000	Cable 2 m	IH03-0B6P0-VU1	6 020 143

Connection Diagram

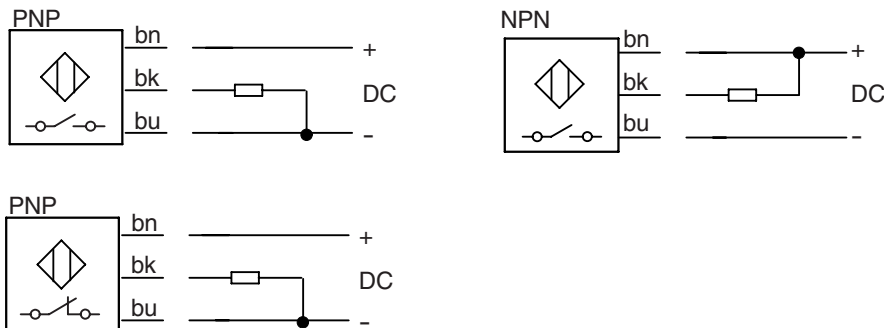

Wire color	Assignment
bn brown	+ V DC
bk black	NO/NC
bu blue	- V DC

IH 04 Miniature

Inductive Proximity Sensors



Highlights

- Shielded
- PNP or NPN output
- Normally open function
- High switching frequency
- Short circuit protection (pulsed)
- Solid stainless steel housing
- Cable or connector
- Enclosure rating IP 67
- LED status indicator

IH 04 Miniature

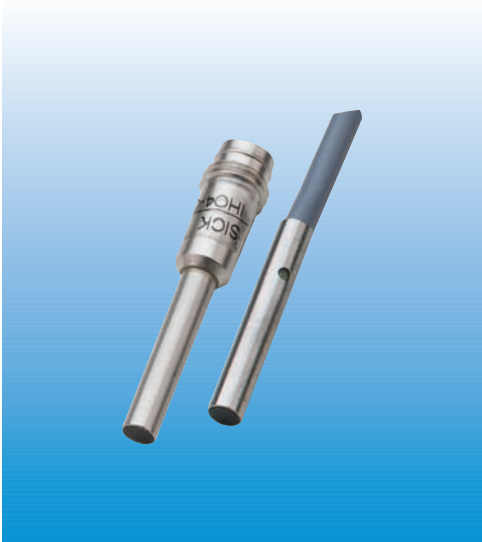

Dimensional Drawing

dimensions in inches (mm)

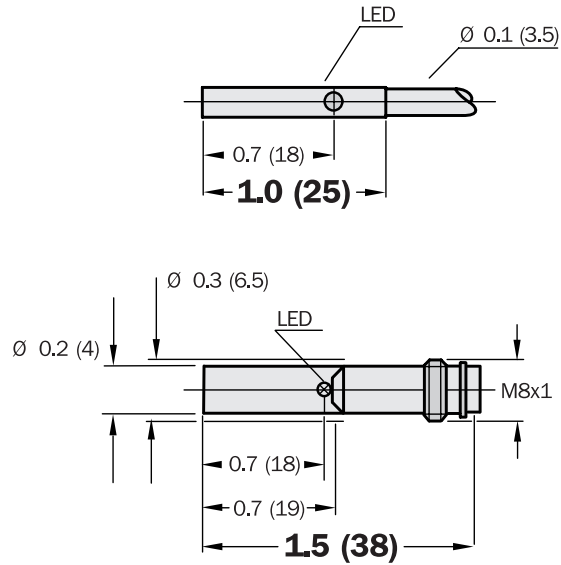

Accessories	page
Cables and connectors	908

Electrical and Mechanical Data

Operating voltage U_b	10...30 V DC
Ripple U_{pp}	$\leq 20\%$ of U_b
Voltage drop U_b	≤ 2.0 V max. at I_a max.
Power consumption (without load)	10 mA
Continuous current I_a	≤ 200 mA
Time delay before availability t_v	≤ 10 ms
Hysteresis H	10% of s_r
Repeatability R (U_b and T_a constant)	$\leq 1.5\%$
Temperature drift	$\pm 10\%$ of s_r
EMC	to EN 60 947-5-2
Short circuit protection (pulsed)	Yes
Reverse polarity protection	Yes
Power-up pulse suppression	Yes
Enclosure rating to DIN 40050	IP 67
Shock and vibration stress	30 g, 11 ms, 10 to 55 Hz, 1 mm
Ambient temperature T_a	-13...158°F (-25...70°C)
Housing material	Stainless steel, plastic
Connection cable	PUR-PVC, 3 x 0.14 mm ²

Selection Table

Sensing range S_n in (mm)	Installation in metal	Switching output	Output function	Switching frequency f in Hz	Connection type	Type	Part no.
0.03 (0.8)		PNP		5000	Cable 2 m	IH04-0B8PS-VW1	6 020 113
0.03 (0.8)		NPN		5000	Cable 2 m	IH04-0B8NS-VW1	6 020 149
0.03 (0.8)		PNP		5000	Connector M8 x 1 mm	IH04-0B8PS-VT1	6 020 114
0.03 (0.8)		NPN		5000	Connector M8 x 1 mm	IH04-0B8NS-VT1	6 020 152

Connection Diagram

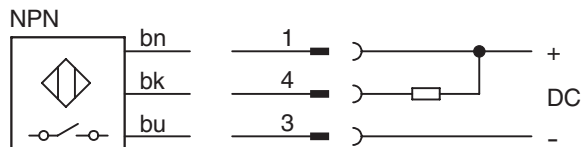
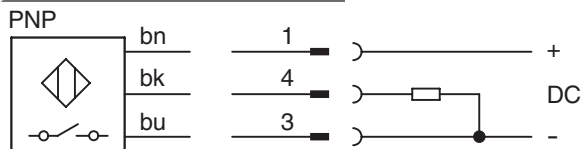

Wire color	Contact	Assignment
bn	1	+ V DC
bk	4	NO
bu	3	- V DC

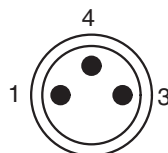

IH 06 Short

Inductive Proximity Sensors



Highlights

- Shielded
- PNP or NPN output
- Normally open function
- High switching frequency
- Short circuit protection (pulsed)
- Solid stainless steel housing
- Cable or connector
- Enclosure rating IP 67
- LED status indicator

IH 06 Short



Dimensional Drawing

dimensions in inches (mm)

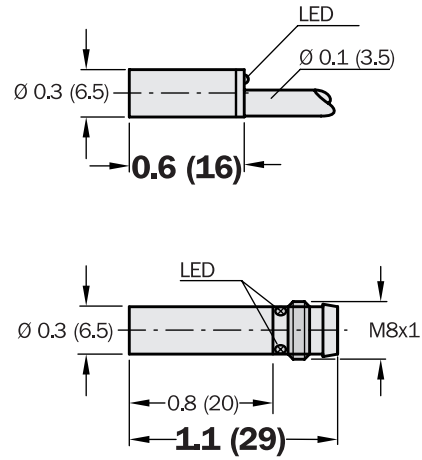

Accessories	page
Cables and connectors	908

Electrical and Mechanical Data

Operating voltage U_b	10...30 V DC
Ripple U_{pp}	$\leq 20\%$ of U_b
Voltage drop U_b	≤ 2.0 V max. at I_a max.
Power consumption (without load)	10 mA
Continuous current I_a	≤ 200 mA
Time delay before availability t_v	≤ 10 ms
Hysteresis H	10% of s_r
Repeatability R (U_b and T_a constant)	$\leq 5\%$
Temperature drift	$\pm 10\%$ of s_r
EMC	to EN 60 947-5-2
Short circuit protection (pulsed)	Yes
Reverse polarity protection	Yes
Power-up pulse suppression	Yes
Enclosure rating to DIN 40050	IP 67
Shock and vibration stress	30 g, 11 ms, 10 to 55 Hz, 1 mm
Ambient temperature T_a	-13...158°F (-25...70°C)
Housing material	Stainless steel, plastic
Connection cable	PVC, 3 x 0.14 mm ²

Selection Table

Sensing range S_n in (mm)	Installation in metal	Switching output	Output function	Switching frequency f in Hz	Connection type	Type	Part no.
0.6 (1.5)		PNP		5000	Cable 2 m	IH06-1B5PS-VWK	6 020 165
0.6 (1.5)		NPN		5000	Cable 2 m	IH06-1B5NS-VWK	6 020 166
0.6 (1.5)		PNP		5000	Cable 2 m	IH06-1B5PO-VWK	6 020 167
0.6 (1.5)		PNP		5000	Connector M8 x 1 mm	IH06-1B5PS-VTK	6 020 169
0.6 (1.5)		NPN		5000	Connector M8 x 1 mm	IH06-1B5NS-VTK	6 020 170
0.6 (1.5)		PNP		5000	Connector M8 x 1 mm	IH06-1B5PO-VTK	6 020 171

Connection Diagram

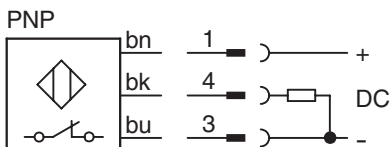

Wire color	Color	Contact	Assignment
bn	brown	1	+ V DC
bk	black	4	NO/NC
bu	blue	3	- V DC

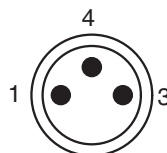

IH 06 Advanced

Inductive Proximity Sensors



Highlights

- Enhanced sensing range
- Solid stainless steel housing
- Shielded or unshielded
- Cable or connector
- PNP or NPN output
- Enclosure rating IP 67
- High switching frequency
- LED status indicator
- Short circuit protection (pulsed)

IH 06 Advanced

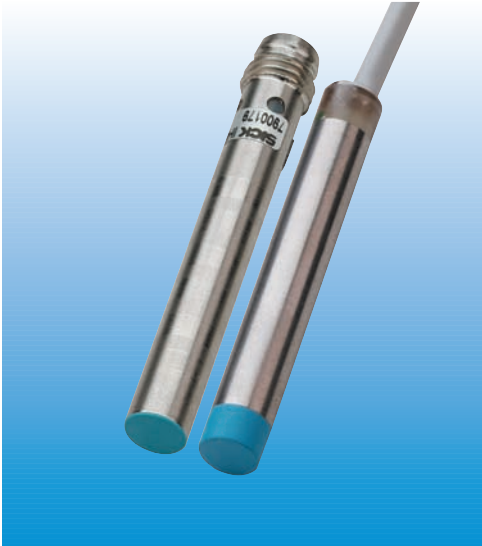

Dimensional Drawing

dimensions in inches (mm)

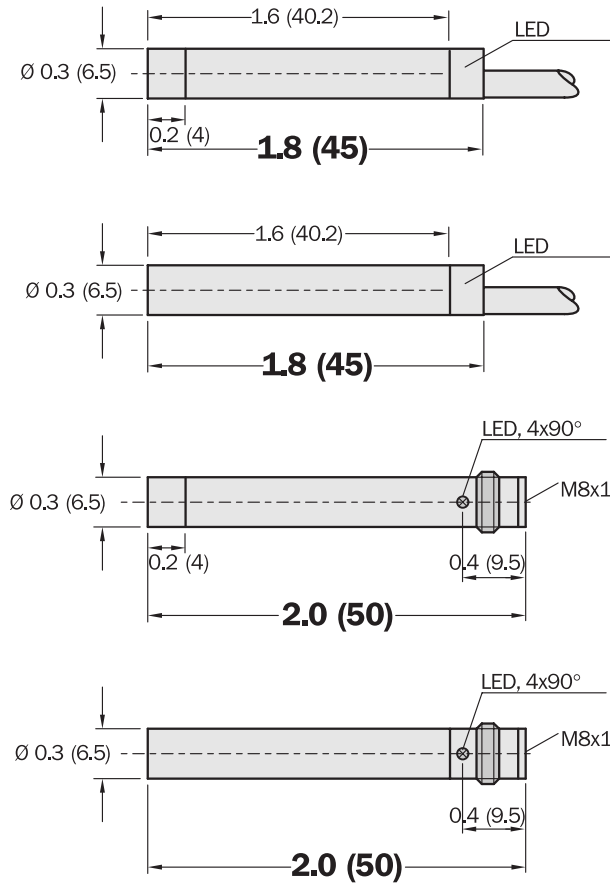

Accessories	page
Cables and connectors	908

Electrical and Mechanical Data

Operating voltage U_b	10...30 V DC
Ripple U_{pp}	$\leq 10\%$ of U_b
Voltage drop U_b	≤ 1.2 V at I_a max.
Power consumption (without load)	≤ 20 mA
Continuous current I_a	≤ 200 mA
Time delay before availability t_v	≤ 100 ms
Hysteresis H	2% - 15% of s_r
Repeatability R (U_b and T_a constant)	$\leq 5\%$ of s_r
Temperature drift	$\pm 10\%$ of s_r
EMC	to EN 60 947-5-2
Wire-break protection	Yes
Short circuit protection (pulsed)	Yes
Reverse polarity protection	Yes
Power-up pulse suppression	Yes
Enclosure rating to DIN 40050	IP 67
Shock and vibration stress	30 g, 11 ms, 10 to 55 Hz, 1 mm
Ambient temperature T_a	-13...167°F (-25...75°C)
Housing material	Stainless steel, plastic
Connection cable	PVC, 3 x 0.14 mm ²

Selection Table

Sensing range S_n in (mm)	Installation in metal	Switching output	Output function	Switching frequency f in Hz	Connection type	Type	Part no.
0.08 (2)		PNP		3000	Cable 2 m	IH06-02BPS-VW1	7 900 177
0.08 (2)		NPN		3000	Cable 2 m	IH06-02BNS-VW1	7 900 178
0.08 (2)		PNP		3000	Connector M8 x 1 mm	IH06-02BPS-VT1	7 900 179
0.08 (2)		NPN		3000	Connector M8 x 1 mm	IH06-02BNS-VT1	7 900 180
0.2 (4)		PNP		3000	Cable 2 m	IH06-04NPS-VW1	7 900181
0.2 (4)		NPN		3000	Cable 2 m	IH06-04NNS-VW1	7 900 182
0.2 (4)		PNP		3000	Connector M8 x 1 mm	IH06-04NPS-VT1	7 900 183

Connection Diagram

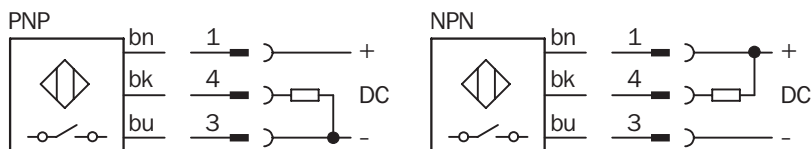

Wire color	Contact	Assignment
bn	brown	1 + V DC
bk	black	4 NO/NC
bu	blue	3 - V DC

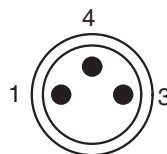

IH 06 Advanced Short

Inductive Proximity Sensors



Highlights

- Enhanced sensing range
- Solid stainless steel housing
- Shielded or unshielded
- Cable or connector
- PNP or NPN output
- Enclosure rating IP 67
- High switching frequency
- LED status indicator
- Short circuit protection (pulsed)

IH 06 Advanced Short

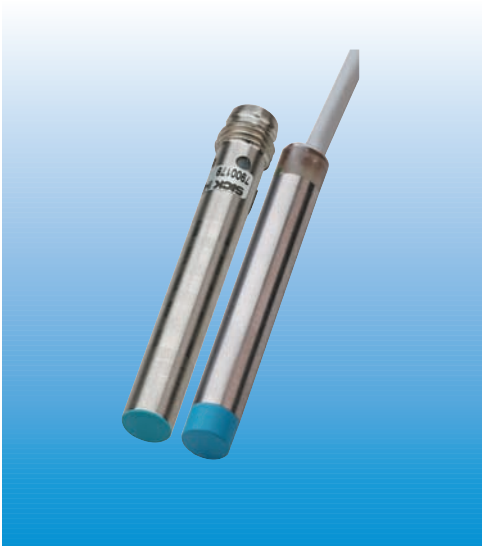

Dimensional Drawing

dimensions in inches (mm)

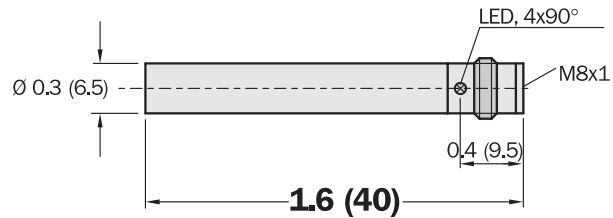
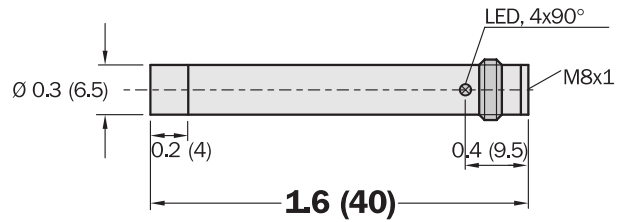
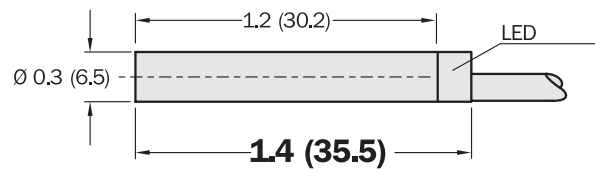
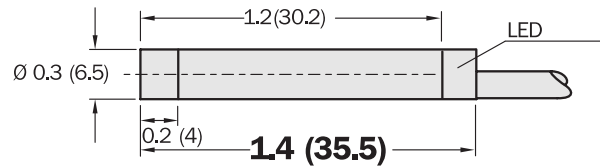

Accessories	page
Cables and connectors	908

Electrical and Mechanical Data

Operating voltage U_b	10...30 V DC
Ripple U_{pp}	$\leq 10\%$ of U_b
Voltage drop U_b	≤ 1.2 V at I_a max.
Power consumption (without load)	≤ 10 mA
Continuous current I_a	≤ 200 mA
Time delay before availability t_v	≤ 5 ms
Hysteresis H	1% - 20% of s_r
Repeatability R (U_b and T_a constant)	$\leq 5\%$ of s_r
Temperature drift	$\pm 10\%$ of s_r
EMC	to EN 60 947-5-2
Short circuit protection (pulsed)	Yes
Reverse polarity protection	Yes
Power-up pulse suppression	Yes
Enclosure rating to DIN 40050	IP 67
Shock and vibration stress	30 g, 11 ms, 10 to 55 Hz, 1 mm
Ambient temperature T_a	-13...160°F (-25...70°C)
Housing material	Stainless steel, plastic
Connection cable	PVC, 3 x 0.14 mm ²

Selection Table

Sensing range S_n in (mm)	Installation in metal	Switching output	Output function	Switching frequency f in Hz	Connection type	Type	Part no.
0.08 (2)		PNP		3000	Cable 2 m	IH06-02BPS-VWK	6 025 874
0.08 (2)		NPN		3000	Cable 2 m	IH06-02BNS-VWK	6 025 874
0.08 (2)		PNP		3000	Connector M8 x 1 mm	IH06-02BPS-VTK	6 025 874
0.08 (2)		NPN		3000	Connector M8 x 1 mm	IH06-02BNS-VTK	6 025 874
0.08 (2)		PNP		3000	Connector M8 x 1 mm	IH06-02BPO-VTK	6 025 874
0.2 (4)		PNP		2500	Cable 2 m	IH06-04NPS-VWK	6 025 874
0.2 (4)		NPN		2500	Cable 2 m	IH06-04NNS-VWK	6 025 874
0.2 (4)		PNP		2500	Connector M8 x 1 mm	IH06-04NPS-VTK	6 025 874
0.2 (4)		NPN		2500	Connector M8 x 1 mm	IH06-04NNS-VTK	6 025 874
0.2 (4)		PNP		2500	Connector M8 x 1 mm	IH06-04NPO-VTK	6 025 874

Connection Diagram

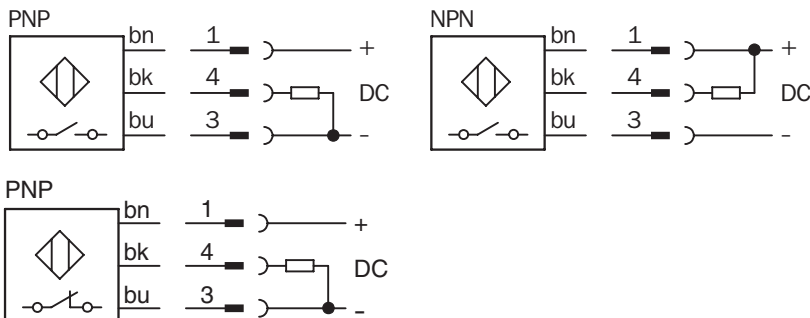

Wire color	Contact	Assignment
bn brown	1	+ V DC
bk black	4	NO/NC
bu blue	3	- V DC

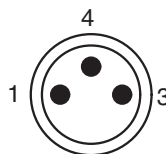

IH 20 Universal

Inductive Proximity Sensors



Highlights

- Unshielded
- Broad operating voltage range in AC and DC
- Short circuit protection (pulsed)
- Plastic housing
- Cable or connector
- Enclosure rating IP 67
- LED status indicator

Dimensional Drawing

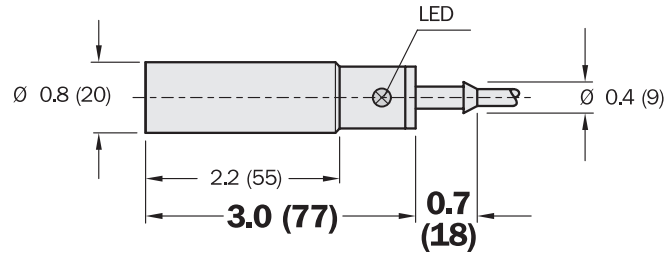

dimensions in inches (mm)



Electrical and Mechanical Data

Operating voltage U_b	20...250 V AC / DC
Voltage drop U_d (at I_a max.)	≤ 6.5 V AC / ≤ 6 V DC
Continuous current I_a	≤ 350 mA AC (... 50°C), ≤ 250 mA AC (...80°C), ≤ 100 mA DC
Peak current I_k	2.2 A (20 ms / 0.5 Hz)
Min. load current	5 mA
Residual current	≤ 2.5 mA (250 V AC), ≤ 1.3 mA (110 V AC), ≤ 0.8 mA (24 V DC)
Time delay before availability t_v	approx. 45 ms
Hysteresis H	1% - 15% of s_r
Repeatability R (U_b and T_a constant)	$\leq 10\%$ of s_r
Temperature drift	$\pm 10\%$ of s_r
EMC	to EN 60 947-5-2
Wire-break protection	-
Short circuit protection (pulsed)	-
Reverse polarity protection	-
Power-up pulse suppression	Yes
Enclosure rating to EN 60529	IP 67
Protection class	<input type="checkbox"/>
Shock and vibration stress	30 g, 11 ms, 10 to 55 Hz, 1 mm
Ambient temperature T_a	-13...176°F (-25...80°C)
Housing material	Plastic
Connection cable	PUR-PVC, 2 x 0.5 mm ²

Selection Table

Sensing range S_n in (mm)	Installation in metal	Switching output	Output function	Switching frequency f in Hz	Connection type	Type	Part no.
0.4 (10)		PNP		25 (AC) / 70 (DC)	Cable 2 m	IH20-10NUS-KU0	7 902 130

Connection Diagram

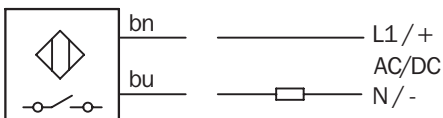

Wire color	Assignment
bn	brown L1 / +
bu	blue N / -

IH 34 Universal

Inductive Proximity Sensors



Highlights

- Enhanced sensing range
- Unshielded
- Broad operating voltage range in AC or DC
- Plastic housing
- Enclosure rating IP 67
- LED status indicator

Dimensional Drawing

dimensions in inches (mm)

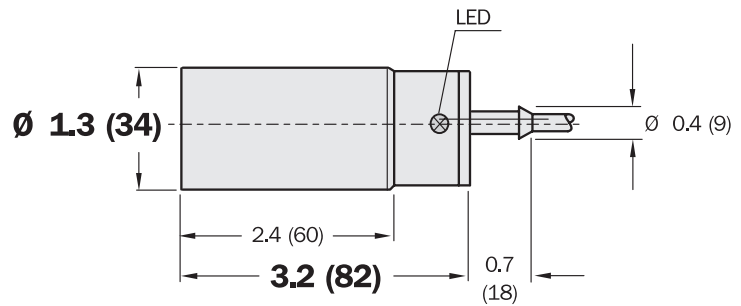

Electrical and Mechanical Data

Operating voltage U_b	20...250 V AC / DC
Voltage drop U_d (at I_a max.)	≤ 6.5 V AC / ≤ 6 V DC
Continuous current I_a	≤ 350 mA AC (... 50°C), ≤ 250 mA AC (...80°C), ≤ 100 mA DC
Peak current I_k	2.2 A (20 ms / 0.5 Hz)
Min. load current	5 mA
Residual current	≤ 2.5 mA (250 V AC), ≤ 1.3 mA (110 V AC), ≤ 0.8 mA (24 V DC)
Time delay before availability t_v	approx. 8 / 50 ms
Hysteresis H	1% - 15% of s_r
Repeatability R (U_b and T_a constant)	$\leq 10\%$ of s_r
Temperature drift	$\pm 10\%$ of s_r
EMC	to EN 60 947-5-2
Wire-break protection	-
Short circuit protection (pulsed)	-
Reverse polarity protection	-
Power-up pulse suppression	Yes
Enclosure rating to EN 60529	IP 67
Protection class	<input type="checkbox"/>
Shock and vibration stress	30 g, 11 ms, 10 to 55 Hz, 1 mm
Ambient temperature T_a	-13...176°F (-25...80°C)
Housing material	Plastic
Connection cable	PUR-PVC, 2 x 0.5 mm ²

Selection Table

Sensing range S_n in (mm)	Installation in metal	Output function	Switching frequency f in Hz	Connection type	Type	Part no.
1.2 (30)			7	Cable 2 m	IH34-30NUS-KU0	7 902 134
1.2 (30)			7	Cable 2 m	IH34-30NU0-KU0	7 902 135

Connection Diagram

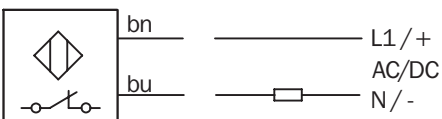
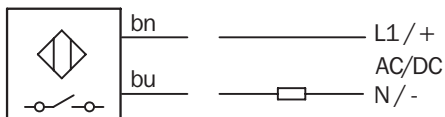

Wire color	Assignment
bn	brown L1 / +
bu	blue N / -

IQ 05 Miniature

Inductive Proximity Sensors



Highlights

- Shielded
- PNP or NPN output
- Normally open function
- High switching frequency
- Short circuit protection (pulsed)
- Robust brass housing, nickel-plated
- Cable
- Enclosure rating IP 67
- LED status indicator

IQ 05 Miniature



Dimensional Drawing

dimensions in inches (mm)

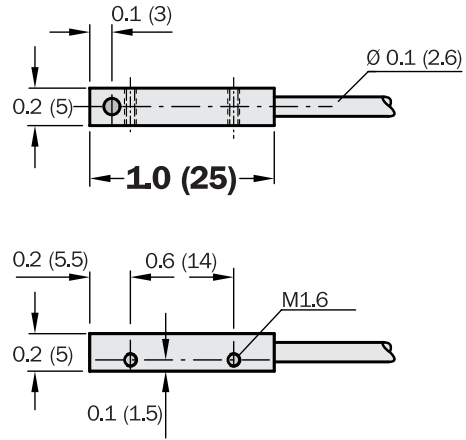

Electrical and Mechanical Data

Operating voltage U_b	10...30 V DC
Ripple U_{pp}	$\leq 20\%$ of U_b
Voltage drop U_b	≤ 2.0 V max. at $I_a = 200$ mA
Power consumption (without load)	≤ 10 mA
Continuous current I_a	≤ 200 mA
Time delay before availability t_v	≤ 10 ms
Hysteresis H	10% of sr
Repeatability R (U_b and T_a constant)	$\leq 1.5\%$ of s_r
Temperature drift	$\pm 10\%$ of s_r
EMC	to EN 60 947-5-2
Short circuit protection (pulsed)	Yes
Reverse polarity protection	Yes
Power-up pulse suppression	Yes
Enclosure rating to DIN 40050	IP 67
Shock and vibration stress	30 g, 11 ms, 10 to 55 Hz, 1 mm
Ambient temperature T_a	-13...158°F (-25...70°C)
Housing material	Brass, nickel-plated, plastic
Connection cable	PUR, 3 x 0.055 mm ²

Selection Table

Sensing range S_n in (mm)	Installation in metal	Switching output	Output function	Switching frequency f in Hz	Connection type	Type	Part no.
0.03 (0.8)		PNP		5000	Cable 2 m	IQ05-0B8PS-ZU1	6 020 161
0.03 (0.8)		NPN		5000	Cable 2 m	IQ05-0B8NS-ZU1	6 020 162
0.03 (0.8)		PNP		5000	Cable 2 m	IQ05-0B8P0-ZU1	6 020 163
0.03 (0.8)		NPN		5000	Cable 2 m	IQ05-0B8N0-ZU1	6 020 164

Connection Diagram

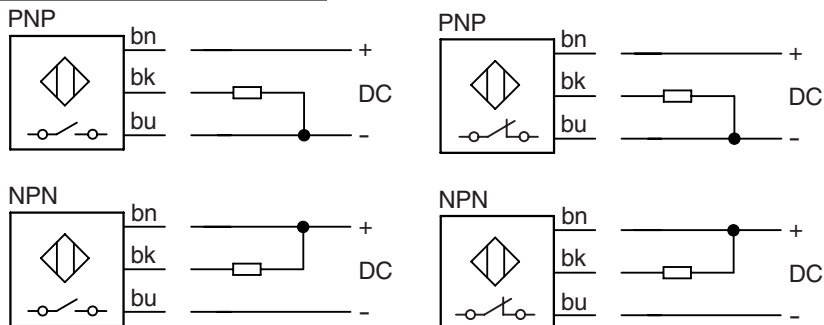

Wire color	Assignment
bn brown	+ V DC
bk black	NO
bu blue	- V DC

IQ 08 Standard

Inductive Proximity Sensors



Highlights

- Shielded or unshielded
- PNP or NPN output
- High switching frequency
- Short circuit protection (pulsed)
- Small plastic housing
- Cable or connector
- Enclosure rating IP 67
- LED status indicator

IQ 08 Advanced



Dimensional Drawing

dimensions in inches (mm)

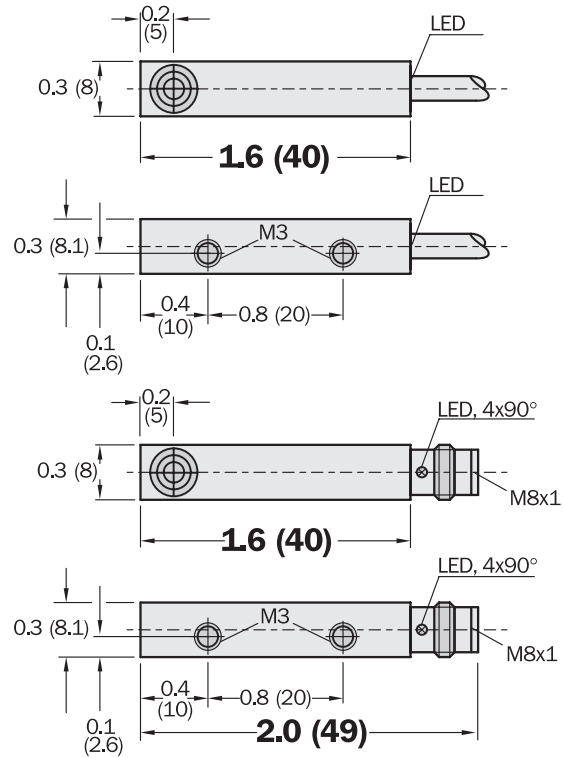

Accessories	page
Cables and connectors	908

Electrical and Mechanical Data

Operating voltage U_b	10...30 V DC
Ripple U_{pp}	$\leq 10\%$ of U_b
Voltage drop U_b	≤ 1.5 V at I_a max.
Power consumption (without load)	≤ 10 mA
Continuous current I_a	≤ 300 mA
Time delay before availability t_v	≤ 2 ms
Hysteresis H	1% - 10% of s_r
Repeatability R (U_b and T_a constant)	$\leq 1\%$ of s_r
Temperature drift	$\pm 10\%$ of s_r
EMC	to EN 60 947-5-2
Wire-break protection	Yes
Short circuit protection (pulsed)	Yes
Reverse polarity protection	Yes
Power-up pulse suppression	Yes
Enclosure rating to DIN 40050	IP 67
Shock and vibration stress	30 g, 11 ms, 10 to 55 Hz, 1 mm
Ambient temperature T_a	-13...167°F (-25...75°C)
Housing material	Plastic
Connection cable	PVC, 3 x 0.25 mm ²

Selection Table

Sensing range S_n in (mm)	Installation in metal	Switching output	Output function	Switching frequency f in Hz	Connection type	Type	Part no.
0.08 (2)		PNP		5000	Cable 2 m	IQ08-02BPS-KU0	7 900 195
0.08 (2)		NPN		5000	Cable 2 m	IQ08-02BNS-KU0	7 900 196
0.08 (2)		PNP		5000	Connector M8 x 1 mm	IQ08-02BPS-KT0	7 900 197
0.08 (2)		NPN		5000	Connector M8 x 1 mm	IQ08-02BNS-KT0	7 900 198
0.2 (4)		PNP		5000	Cable 2 m	IQ08-04NPS-KU0	7 900 199
0.2 (4)		PNP		5000	Connector M8 x 1 mm	IQ08-04NPS-KT0	7 900 201

Connection Diagram

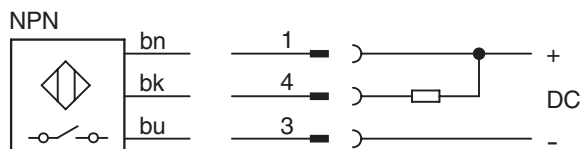
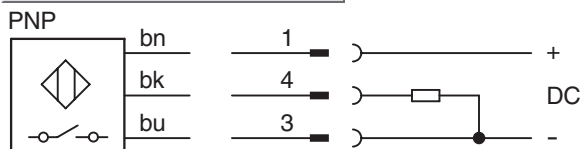

Wire color	Contact	Assignment
bn	brown	1 + V DC
bk	black	4 NO
bu	blue	3 - V DC

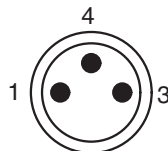

IQ 10 Standard

Inductive Proximity Sensors



Highlights

- Shielded or unshielded
- PNP or NPN output
- High switching frequency
- Short circuit protection (pulsed)
- Plastic housing
- Cable or connector
- Enclosure rating IP 67
- LED status indicator

IQ 10 Advanced



Dimensional Drawing

dimensions in inches (mm)

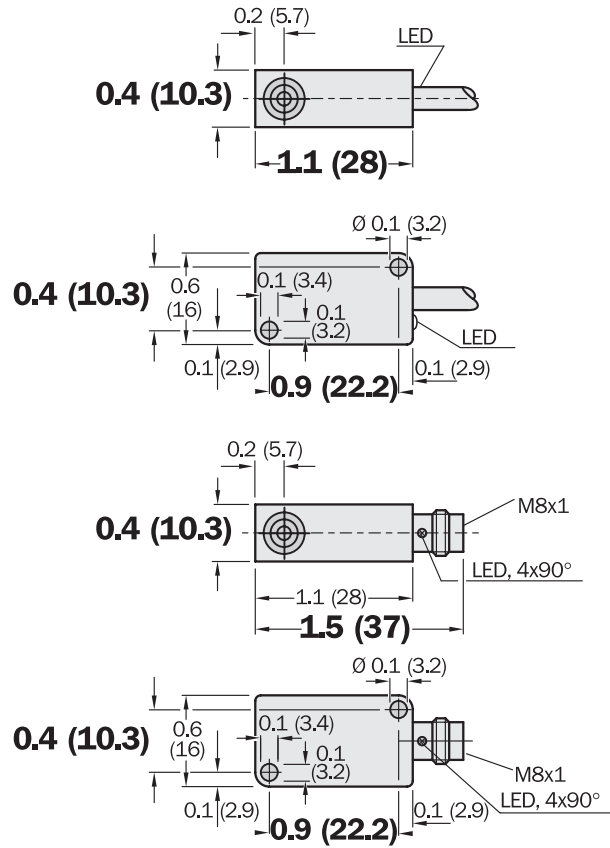

Accessories	page
Cables and connectors	908

Electrical and Mechanical Data

Operating voltage U_b	10...30 V DC
Ripple U_{pp}	$\leq 10\%$ of U_b
Voltage drop U_b	≤ 1.5 V at I_a max.
Power consumption (without load)	≤ 10 mW
Continuous current I_a	≤ 300 mA
Time delay before availability t_v	≤ 2 ms
Hysteresis H	1% - 10% of s_r
Repeatability R (U_b and T_a constant)	$\leq 1\%$ of s_r
Temperature drift	$\pm 10\%$ of s_r
EMC	to EN 60 947-5-2
Wire-break protection	Yes
Short circuit protection (pulsed)	Yes
Reverse polarity protection	Yes
Power-up pulse suppression	Yes
Enclosure rating to DIN 40050	IP 67
Shock and vibration stress	30 g, 11 ms, 10 to 55 Hz, 1 mm
Ambient temperature T_a	-13...167°F (-25...75°C)
Housing material	Plastic
Connection cable	PVC, 3 x 0.25 mm ²

Selection Table

Sensing range S_n in (mm)	Installation in metal	Switching output	Output function	Switching frequency f in Hz	Connection type	Type	Part no.
0.1 (3)		PNP		3000	Cable 2 m	IQ10-03BPS-KU0	7 900 203
0.1 (3)		NPN		3000	Cable 2 m	IQ10-03BNS-KU0	7 900 204
0.1 (3)		PNP		3000	Connector M8 x 1 mm	IQ10-03BPS-KT0	7 900 205
0.1 (3)		NPN		3000	Connector M8 x 1 mm	IQ10-03BNS-KT0	7 900 206
0.2 (6)		PNP		3000	Cable 2 m	IQ10-06NPS-KU0	7 900 207
0.2 (6)		NPN		3000	Cable 2 m	IQ10-06NNS-KU0	7 900 208
0.2 (6)		PNP		3000	Connector M8 x 1 mm	IQ10-06NPS-KT0	7 900 209
0.2 (6)		NPN		3000	Connector M8 x 1 mm	IQ10-06NNS-KT0	7 900 210

Connection Diagram

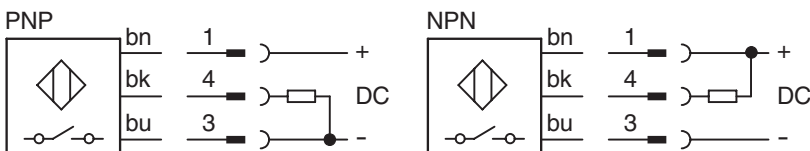

Wire color	Contact	Assignment
bn	1	+ V DC
bk	4	NO
bu	3	- V DC

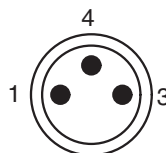

IQ 12 Standard

Inductive Proximity Sensors



Highlights

- Shielded or unshielded
- PNP or NPN output
- High switching frequency
- Short circuit protection (pulsed)
- Plastic housing
- Cable or connector
- Enclosure rating IP 67
- LED status indicator

IQ 12 Advanced

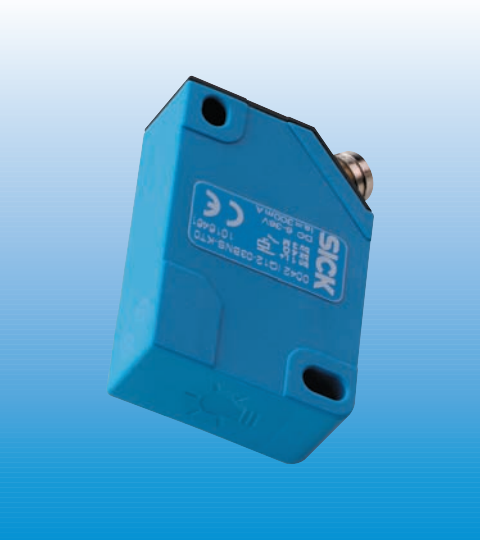

Dimensional Drawing

dimensions in inches (mm)

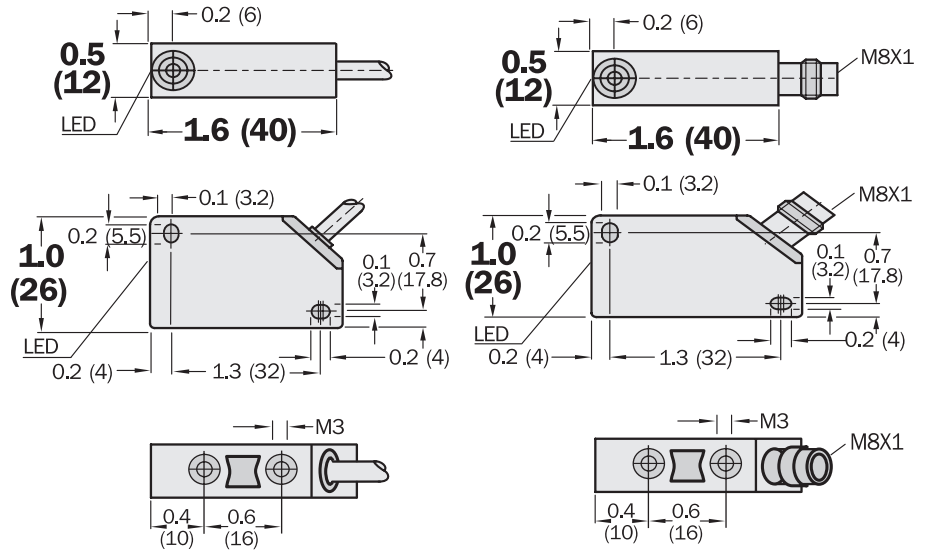

Accessories	page
Cables and connectors	908

Electrical and Mechanical Data

Operating voltage U_b	6...30 V DC
Ripple U_{pp}	$\leq 10\%$ of U_b
Voltage drop U_b	≤ 1.5 V at I_a max.
Power consumption (without load)	≤ 5 mA
Continuous current I_a	≤ 300 mA
Time delay before availability t_v	≤ 10 ms
Hysteresis H	1% - 15% of s_r
Repeatability R (U_b and T_a constant)	$\leq 1\%$ of s_r
Temperature drift	$\pm 10\%$ of s_r
EMC	to EN 60 947-5-2
Wire-break protection	Yes
Short circuit protection (pulsed)	Yes
Reverse polarity protection	Yes
Power-up pulse suppression	Yes
Enclosure rating to DIN 40050	IP 67
Shock and vibration stress	30 g, 11 ms, 10 to 55 Hz, 1 mm
Ambient temperature T_a	-13...167°F (-25...75°C)
Housing material	Plastic
Connection cable	PVC, 3 x 0.25 mm ²

Selection Table

Sensing range S_n in (mm)	Installation in metal	Switching output	Output function	Switching frequency f in Hz	Connection type	Type	Part no.
0.1 (3)		PNP		3000	Cable 2 m	IQ12-03BPS-KW1	1 016 275
0.1 (3)		NPN		3000	Cable 2 m	IQ12-03BNS-KW1	1 016 299
0.1 (3)		PNP		3000	Connector M8 x 1 mm	IQ12-03BPS-KT1	1 016 276
0.1 (3)		NPN		3000	Connector M8 x 1 mm	IQ12-03BNS-KT1	1 016 461
0.2 (6)		PNP		1000	Cable 2 m	IQ12-06NPS-KW1	1 016 463
0.2 (6)		PNP		1000	Connector M8 x 1 mm	IQ12-06NPS-KT1	1 016 467

Connection Diagram

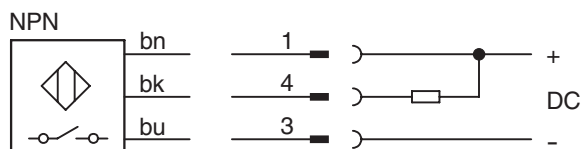
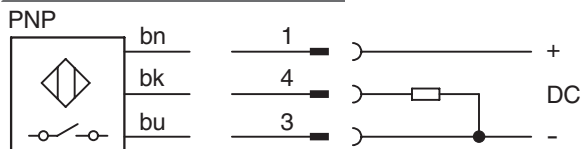

Wire color	Contact	Assignment
bn	brown	1 + V DC
bk	black	4 NO
bu	blue	3 - V DC

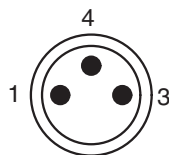

IQ 40 Short

Inductive Proximity Sensors



IQ 40 Short



Highlights

- Shielded or unshielded
- User-selectable sensing position, adjusts to any of 5 sensing directions
- PNP output
- NO and complementary output function
- Short circuit protection (pulsed)
- Plastic housing
- Connector
- Enclosure rating IP 67
- LED status indicator and LED function indicator

Dimensional Drawing

dimensions in inches (mm)

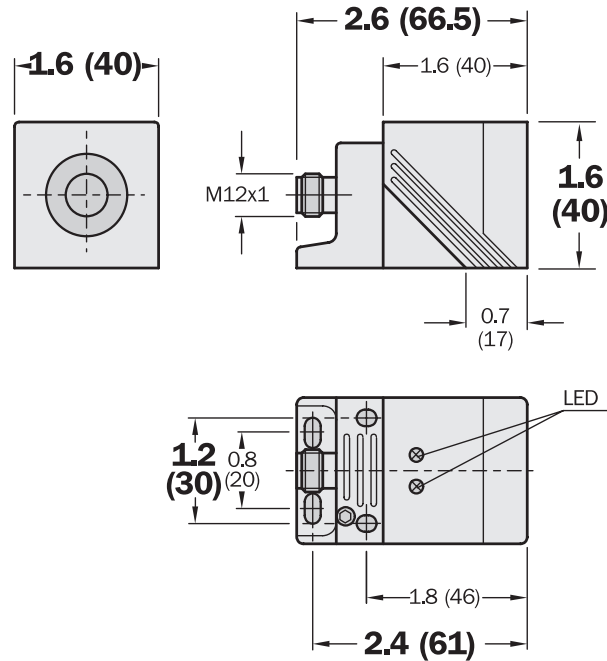

Accessories	page
Cables and connectors	909

Electrical and Mechanical Data

Operating voltage U_b	10...36 V DC
Voltage drop U_b	≤ 2.5 V at I_a max. and U_b 24 V
Power consumption (without load)	≤ 15 mA
Continuous current I_a	≤ 250 mA
Time delay before availability t_v	approx. 4 ms
Hysteresis H	1% - 15% of s_r
Repeatability R (U_b and T_a constant)	$\leq 10\%$ of s_r
Temperature drift	$\pm 10\%$ of s_r
EMC	to EN 60 947-5-2
Short circuit protection (pulsed)	Yes
Reverse polarity protection	Yes
Power-up pulse suppression	Yes
Protection class	<input type="checkbox"/>
Enclosure rating to DIN 40050	IP 67
Shock and vibration stress	30 g, 11 ms, 10 to 55 Hz, 1 mm
Ambient temperature T_a	-13...158°F (-25...70°C)
Housing material	Plastic

Selection Table

Sensing range S_n in (mm)	Installation in metal	Switching output	Output function	Switching frequency f in Hz	Connection type	Type	Part no.
0.6 (15)		PNP		200	Connector M12 x 1 mm	IQ40-15BPS-KC0	7 900 223
0.8 (20)		PNP		300	Connector M12 x 1 mm	IQ40-20BPP-KCK	6 012 014
1.4 (35)		PNP		100	Connector M12 x 1 mm	IQ40-35NPS-KC0	7 900 224
1.4 (35)		PNP		100	Connector M12 x 1 mm	IQ40-35NPP-KCK	6 012 015

Connection Diagram

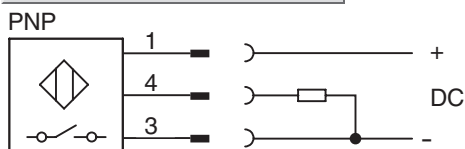

Contact	Assignment
1	+ V DC
4	NO
3	- V DC
2	free

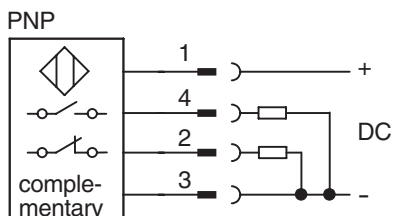
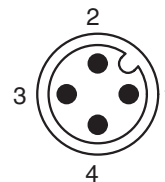

Contact	Assignment
1	+ V DC
2	NC
3	- V DC
4	NO

IQ 40 Standard

Inductive Proximity Sensors



Highlights

- Shielded or unshielded
- User-selectable sensing position, adjusts to any of 5 sensing directions
- PNP output
- Programmable NO/NC function
- Short circuit protection (pulsed)
- Plastic housing
- Terminal connection
- Enclosure rating IP 65
- LED status indicator

IQ 40 Advanced



Dimensional Drawing

dimensions in inches (mm)

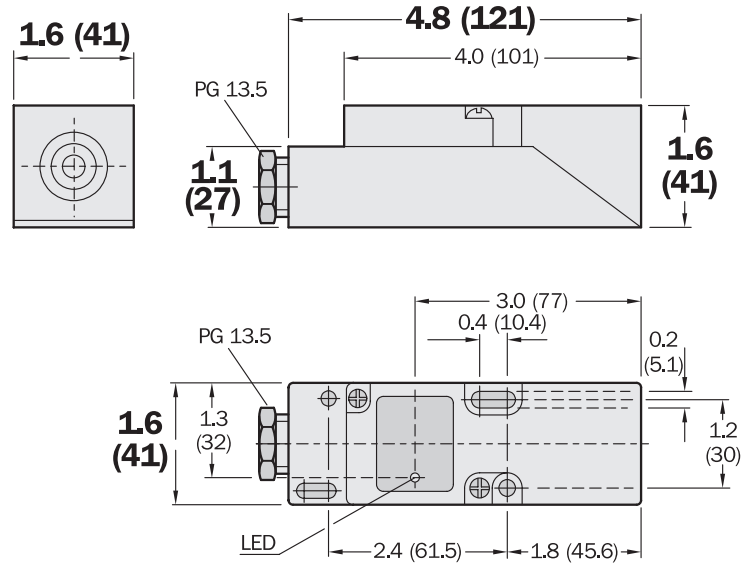

Electrical and Mechanical Data

Operating voltage U_b	10...36 V DC
Voltage drop U_b	≤ 2.5 V at I_a max. and U_b 24 V
Power consumption (without load)	≤ 15 mA
Continuous current I_a	≤ 250 mA
Time delay before availability t_v	approx. 4 ms
Hysteresis H	1% - 15% of s_r
Repeatability R (U_b and T_a constant)	$\leq 10\%$ of s_r
Temperature drift	$\pm 10\%$ of s_r
EMC	to EN 60 947-5-2
Short circuit protection (pulsed)	Yes
Reverse polarity protection	Yes
Power-up pulse suppression	Yes
Enclosure rating to DIN 40050	IP 65
Protection class	<input type="checkbox"/>
Shock and vibration stress	30 g, 11 ms, 10 to 55 Hz, 1 mm
Ambient temperature T_a	13...176°F (-25...80°C)
Housing material	Plastic

Selection Table

Sensing range S_n in (mm)	Installation in metal	Switching output	Output function	Switching frequency f in Hz	Connection type	Type	Part no.
0.6 (15)		PNP	 programmable	300	Terminal up to 2.5 mm ²	IQ40-15BPP-KK0	7 900 219
0.8 (20)		PNP	 programmable	300	Terminal up to 2.5 mm ²	IQ40-20NPP-KK0	7 900 221

Connection Diagram

PNP

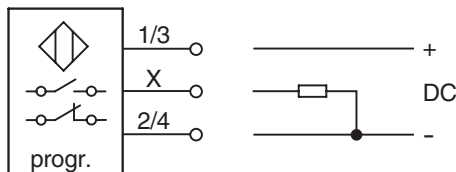

Programming with wirelinks

Link closed: NO
Link open: NC

Terminal	Assignment
1/3	+ V DC
X	NO/NC
2/4	- V DC

IQ 40 Universal

Inductive Proximity Sensors



Highlights

- Shielded or unshielded
- User-selectable sensing position, adjusts to any of 5 sensing directions
- Broad operating voltage range in AC and DC
- Programmable switching output: NO or NC
- Plastic housing
- Enclosure rating IP 65
- Terminal connection
- LED status indicator

IQ 40 Universal

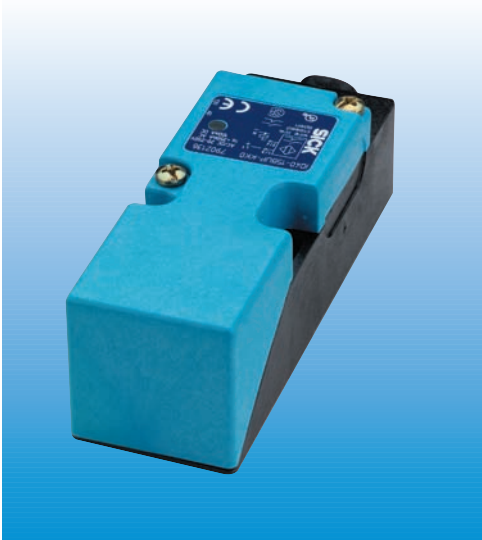

Dimensional Drawing

dimensions in inches (mm)

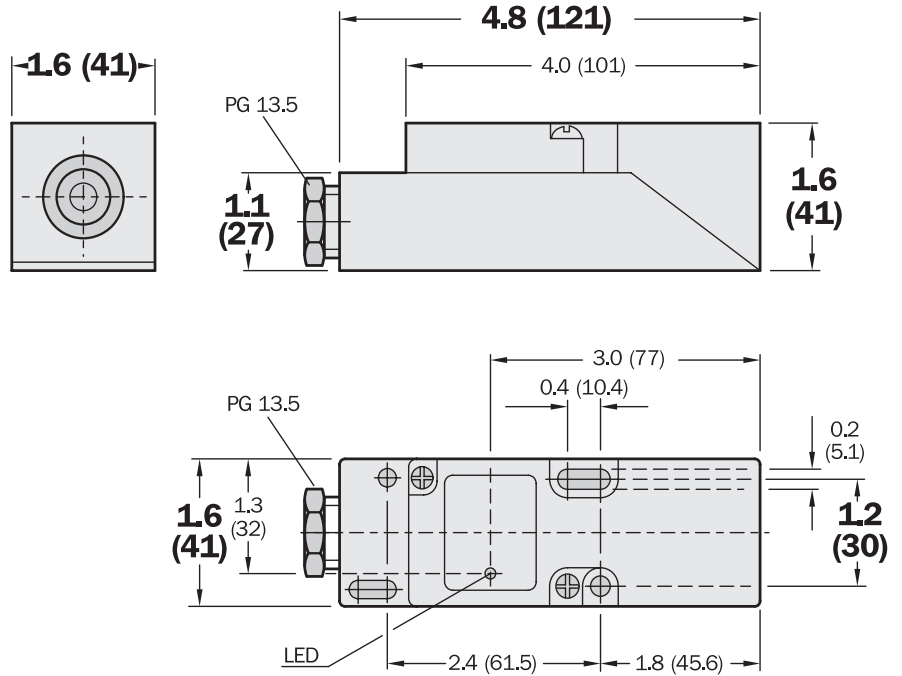

Electrical and Mechanical Data

Operating voltage U_b	20...250 V AC / DC
Voltage drop U_b	≤ 6.5 V AC / ≤ 6 V DC with I_a max.
Continuous current I_a	≤ 350 mA AC (...+50°C), ≤ 250 mA AC (...+80°C), ≤ 100 mA DC
Peak current I_k	2.2 A (20 ms / 0.5 Hz)
Min. load current	5 mA
Residual current	≤ 2.5 mA (250 V AC), ≤ 1.3 mA (110 V AC), ≤ 0.8 mA (24 V DC)
Time delay before availability t_v	approx. 8 ms
Hysteresis H	1% - 15% of s_r
Repeatability R (U_b and T_a constant)	$\leq 10\%$ of s_r
Temperature drift	$\pm 10\%$ of s_r
EMC	to EN 60 947-5-2
Wire-break protection	-
Short circuit protection (pulsed)	-
Reverse polarity protection	-
Power-up pulse suppression	Yes
Enclosure rating to DIN 40050	IP 65
Protection class	<input type="checkbox"/>
Shock and vibration stress	30 g, 11 ms, 10 to 55 Hz, 1 mm
Ambient temperature T_a	13...176°F (-25...80°C)
Housing material	Plastic

Selection Table

Sensing range S_n in (mm)	Installation in metal	Output function	Switching frequency f in Hz	Connection	Type	Part no.
0.6 (15)		 programmable	20 (AC) / 55 (DC)	Terminal up to 2.5mm ²	IQ40-15BUP-KK0	7 902 136
0.8 (20)		 programmable	20 (AC) / 55 (DC)	Terminal up to 2.5mm ²	IQ40-20NUP-KK0	7 902 137

Connection Diagram

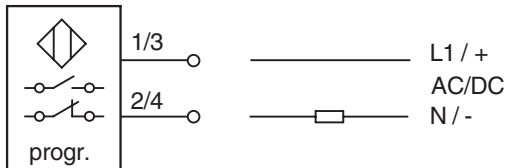

Programming with wire links

Link closed: NO
Link open: NC

Terminal	Assignment
1/3	L1 / +
2/4	N / -

IQ 80 Standard

Inductive Proximity Sensors



Highlights

- Unshielded
- Adjustable sensing distance from 20 to 60 mm
- PNP output
- Programmable NO/NC function
- Short circuit protection (pulsed)
- Robust plastic housing
- Terminal connection
- Enclosure rating IP 65
- LED status indicator

IQ 80 Advanced



Dimensional Drawing

dimensions in inches (mm)

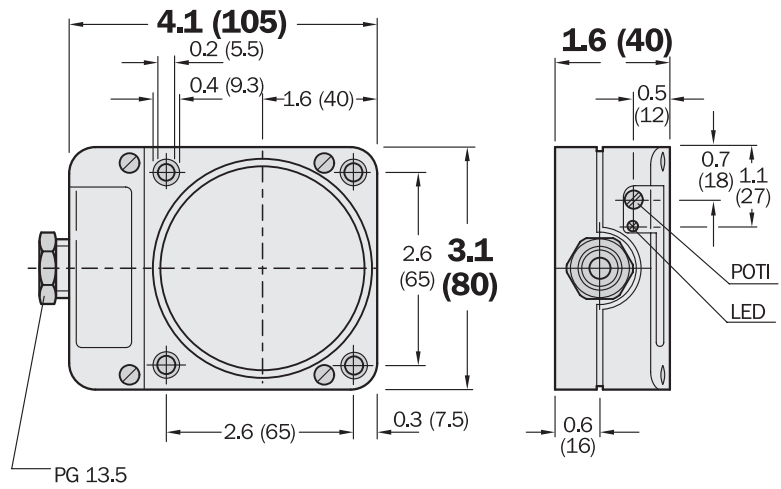

Electrical and Mechanical Data

Operating voltage U_b	10...36 V DC
Voltage drop U_b	≤ 2.5 V at I_a max. and U_b 24 V
Power consumption (without load)	≤ 15 mA
Continuous current I_a	≤ 250 mA
Time delay before availability t_v	approx. 250 ms
Hysteresis H	1% - 15% of s_r
Repeatability R (U_b and T_a constant)	$\leq 10\%$ of s_r
Temperature drift	$\pm 10\%$ of s_r
EMC	to EN 60 947-5-2
Short circuit protection (pulsed)	Yes
Reverse polarity protection	Yes
Power-up pulse suppression	Yes
Enclosure rating to DIN 40050	IP 65
Protection class	<input type="checkbox"/>
Shock and vibration stress	30 g, 11 ms, 10 to 55 Hz, 1 mm
Ambient temperature T_a	13...176°F (-25...80°C)
Housing material	Plastic

Selection Table

Sensing range S_n in (mm)	Installation in metal	Switching output	Output function	Switching frequency f in Hz	Connection type	Type	Part no.
2.4 (60)		PNP	 programmable	4	Terminal up to 2.5 mm ²	IQ80-60NPP-KK0	7 900 227

Connection Diagram

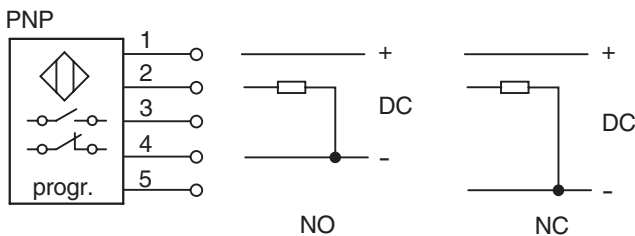

Terminal	Assignment
1	+ V DC
2	Output
3	free
4	- V DC/ NO
5	- V DC/ NC

IQ 80 Universal

Inductive Proximity Sensors



Highlights

- Unshielded
- Adjustable sensing distance from 20 to 60 mm
- Broad operating voltage range in AC and DC
- Robust plastic housing
- Programmable switching output: NO or NC
- Enclosure rating IP 65
- Terminal connection
- LED status indicator

IQ 80 Universal

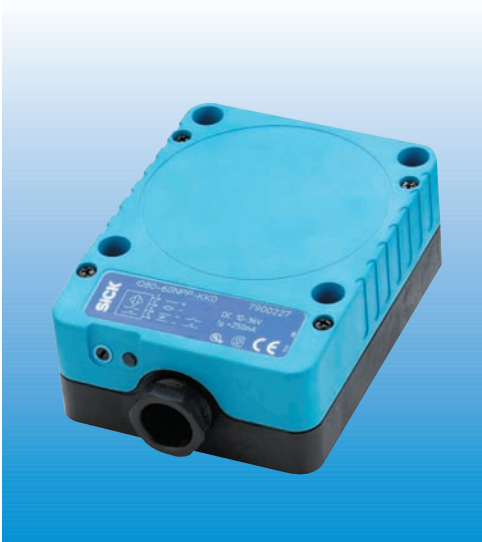

Dimensional Drawing

dimensions in inches (mm)

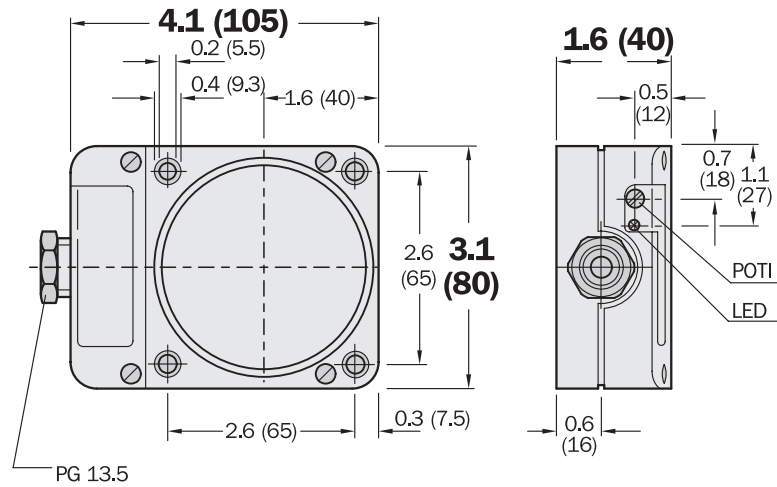

Electrical and Mechanical Data

Operating voltage U_b	20...250 V AC / DC
Voltage drop U_b	≤ 6.5 V AC / ≤ 6 V DC with I_a max.
Continuous current I_a	≤ 350 mA AC (...+50°C), ≤ 250 mA AC (...+80°C), ≤ 100 mA DC
Peak current I_k	2.2 A (20 ms / 0.5 Hz)
Min. load current	5 mA
Residual current	≤ 2.5 mA (250 V AC), ≤ 1 mA (24 V DC)
Time delay before availability t_v	approx. 8 ms
Hysteresis H	1% - 15% of s_r
Repeatability R (U_b and T_a constant)	$\leq 10\%$ of s_r
Temperature drift	$\pm 10\%$ of s_r
EMC	to EN 60 947-5-2
Wire-break protection	-
Short circuit protection (pulsed)	-
Reverse polarity protection	-
Power-up pulse suppression	Yes
Enclosure rating to DIN 40050	IP 65
Protection class	<input type="checkbox"/>
Shock and vibration stress	30 g, 11 ms, 10 to 55 Hz, 1 mm
Ambient temperature T_a	13...176°F (-25...80°C)
Housing material	Plastic

Selection Table

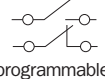
Sensing range S_n in (mm)	Installation in metal	Output function	Switching frequency f in Hz	Connection	Type	Part no.
2.4 (60)		 programmable	4	Terminal up to 2.5 mm ²	IQ80-60NUP-KK0	7 902 138

Connection Diagram

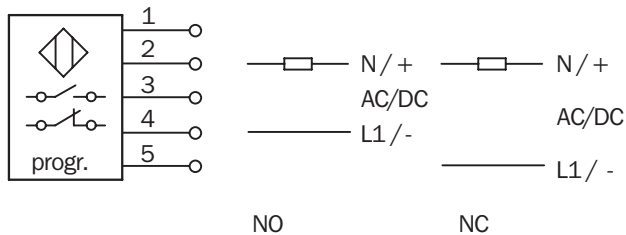

Terminal	Assignment
1	free
2	N/+
3	free
4	L1/- (NO)
5	L1/- (NC)