

BFF3302 SENSOR AND INSTRUMENTATION SYSTEM

Operational Amplifier

By

Ahmad Shahrizan Abdul Ghani (shahrizan@ump.edu.my)

Nafrizuan Bin Mat Yahya (nafrizuanmy@ump.edu.my)

Faculty of Manufacturing Engineering (FKP)

Chapter Description

- Aims
 - Obtain basic knowledge about signal conditioning elements
- Expected Outcomes
 - Understanding the characteristic and usage of signal conditioning elements.
- References
 - B.C.Nakra and K.K. Chaudhry, 2012. Instrumentation measurement and analysis, 3rd ed., Tata-McGraw-Hill.
 - Introduction to signal processing, instrumentation, and control : an integrative approach / Joseph Bentsman Hackensack, NJ : World Scientific Pub., 2016
 - Transducers for instrumentation / M. G. Joshi, New Delhi, India : Infinity, 2017
 - Instrumentation and measurement in electrical engineering / editor : Harinirina Randrianarisoa, New York : Arcler Press, 2017



Operational amplifier

- OP-AMP are special type of amplifier.
- They are termed **operational** because they were originally developed for **math. Operations** in computer such as adding, subtracting..etc.
- They are the basic building blocks of most electronic signal conditioning circuit.
- In the form of integrated circuits, they are relatively **inexpensive**, precise and reliable.
- The op-amp circuitry → consists of **diodes, transistors, resistors, couple capacitors.**

Operational amplifier

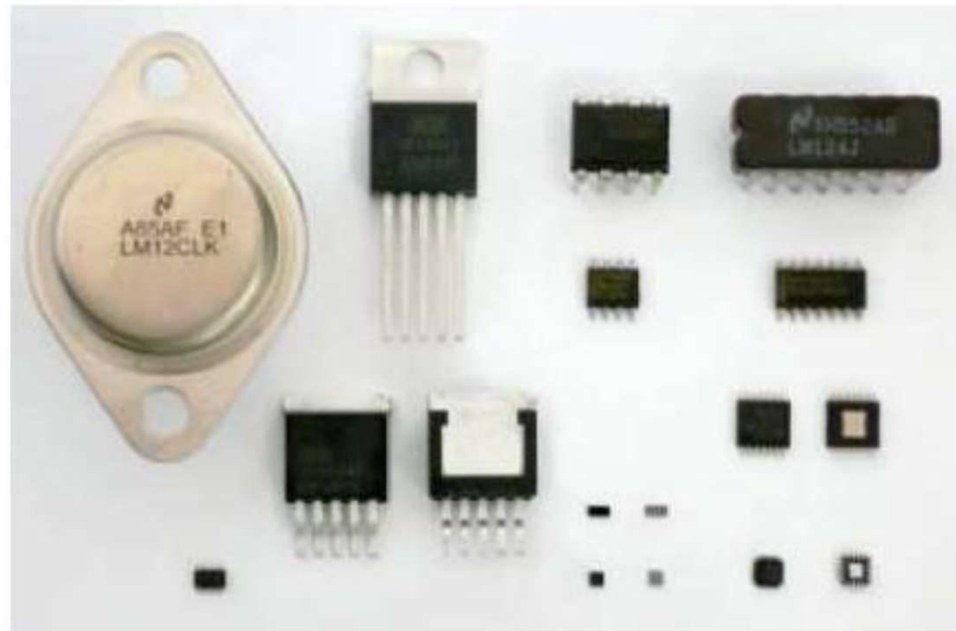
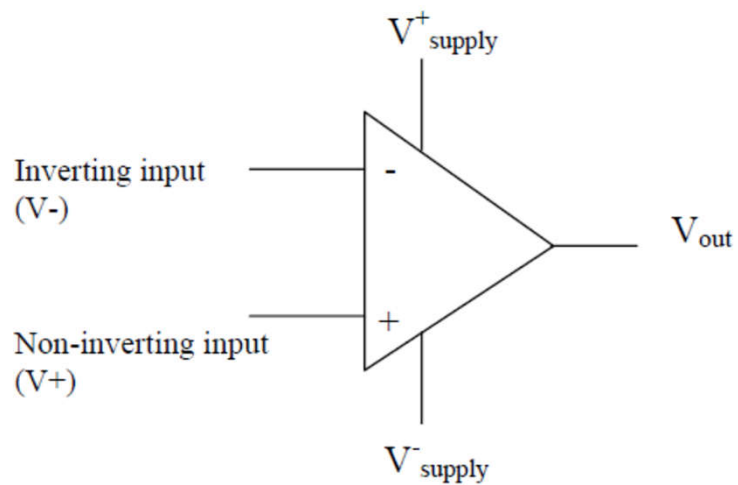

Ideal Op-Amp

Parameter Name	Symbol	Value
Input impedance	R_{in}	∞
Output impedance	R_{out}	0
Open-loop gain	G	∞

- Temperature-independent.

$$V_{out} = G(V_+ - V_-) = G \cdot V_{in}$$

- The maximum output voltage value is the supply voltage (saturation):

$$-V_{S-} \leq V_{out} \leq V_{S+}$$

- What this means:

- Current flow into the op-amp from either input terminal is zero.

- $I_- = I_+ = 0$

- Differential voltage, $(V_+ - V_-)$ between the two input terminals is zero.

- $V_+ - V_- = 0$

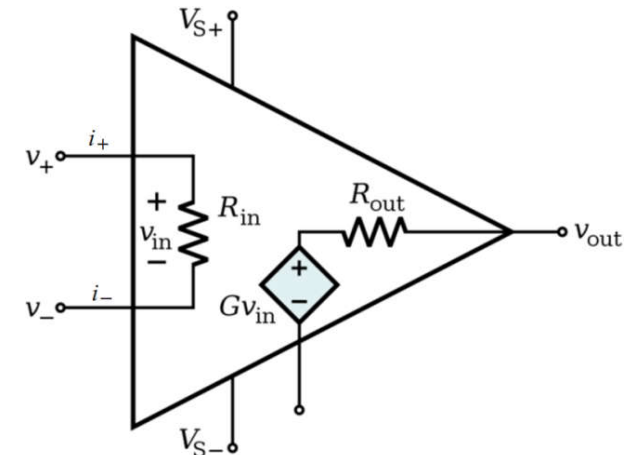

Operational amplifiers

- An operational amplifier (op-amp) has the following characteristics:
 - **High gain** dc difference amplifier type, having two inputs terminals and act on a difference in voltages at the terminals (>100000 , ideally = infinite)
 - Available as an integrated circuit (IC)
 - **High input impedance** (ideal: infinite)
 - **Low output impedance** (ideal: zero; practical value: 20-100 Ω)
 - Normally used along with outside resistance and capacitances.

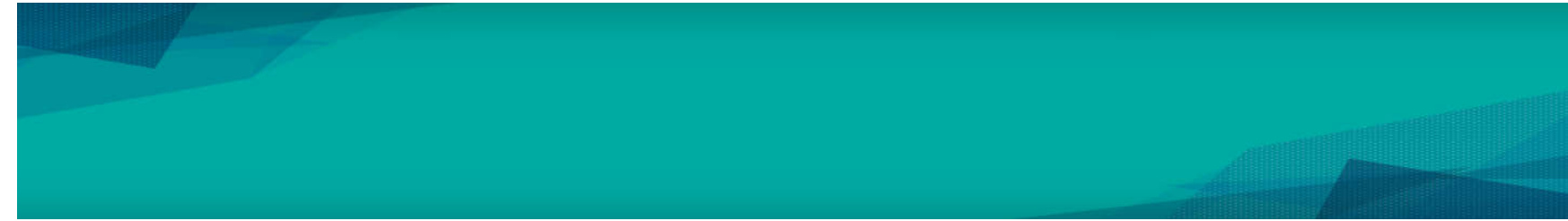

- V_{S+} : +ve power supply
- V_{S-} : -ve power supply
- V_+ : non-inverting input terminal
- V_- : inverting input terminal
- V_{out} : output terminal
 - V_+, V_-, V_{out} are all referenced to ground

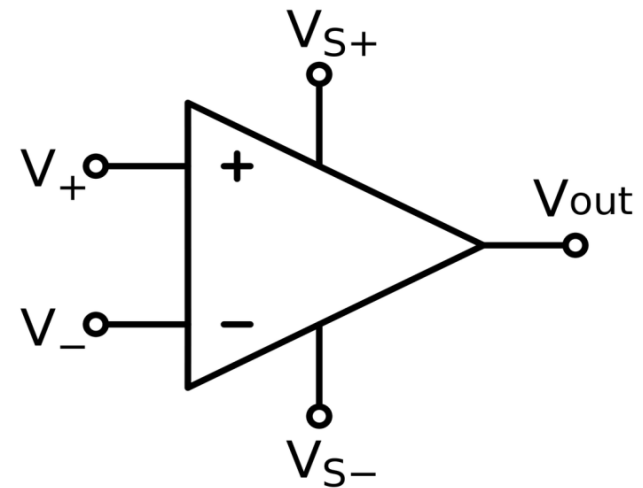

Operational amplifiers

- A typical op-amp IC has several elements:
- 20 transistors
- 12 resistors
- 1 capacitor
- The performance is gain up to 10^5 , depending on frequency
- Power supply 18V
- Maximum differential input 30V
- Maximum signal ended input 15V
- Input offset voltage 2mV

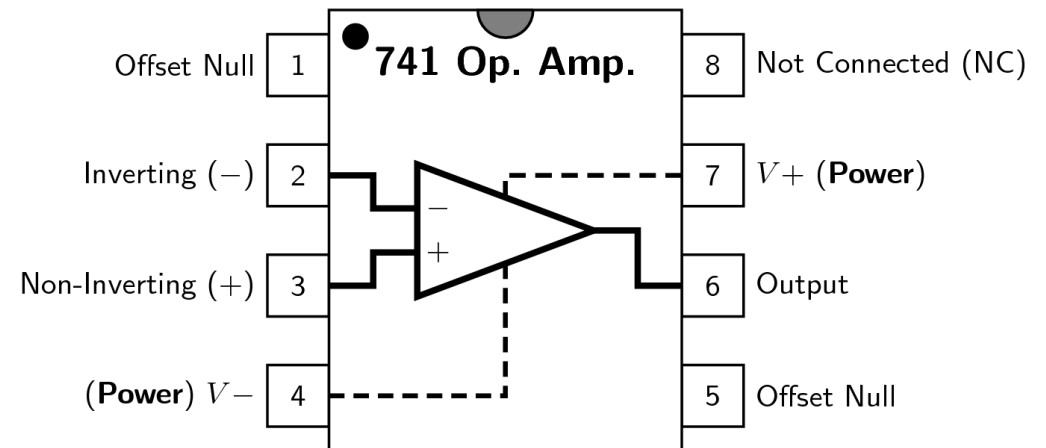
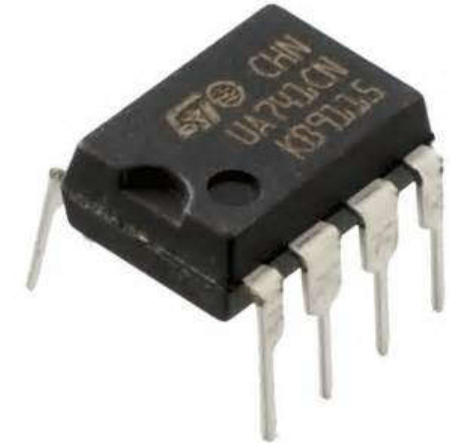

Operational amplifiers

- These amplifier are used in several applications:
 - Amplification
 - Summing and difference amplification
 - Integrating
 - Differentiating
 - Charge amplifiers
 - Sensor linearization

Operational amplifiers

- The input voltages are e_1 and e_2 and output e_0 , all measured relative to the ground.
- Input e_1 is called inverting input (-ve)
- Input e_2 is called non-inverting input (+ve)

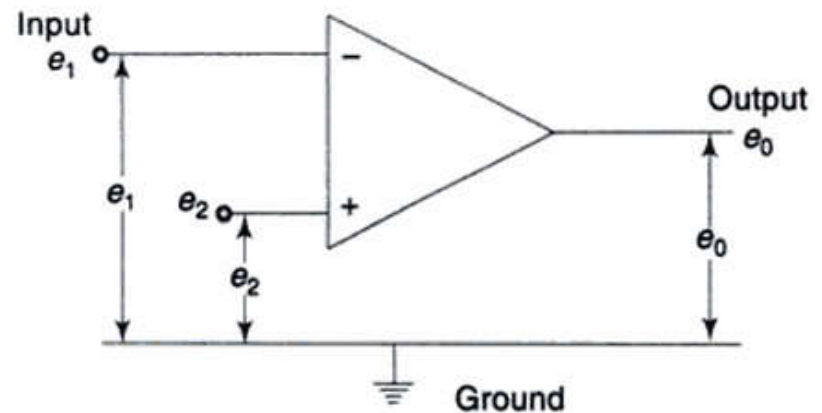

B.C.Nakra and K.K. Chaudhry, 2012. Instrumentation measurement and analysis, 3rd ed., Tata-McGraw-Hill.

Fig. 5.10 Representation of an operational amplifier

Inverting amplifier

Functionality: to amplify the input voltage to output voltage with a negative gain.

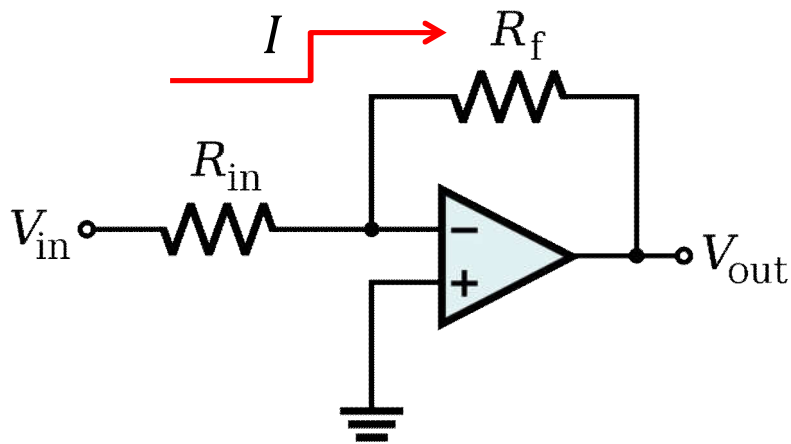

$$\begin{aligned}V_+ &= 0\text{ V} \\V_{in} &= V_- = R_{in} \cdot I \\V_{out} &= R_f \cdot (-I) \\ \frac{V_{out}}{V_{in}} &= \frac{-I \cdot R_f}{I \cdot R_{in}} \\V_{out} &= -\frac{R_f}{R_{in}} \cdot V_{in}\end{aligned}$$

Non-inverting amplifier

- Functionality: to amplify the input voltage to output voltage with a positive gain.

- $V_{in} = V_- = V_+$
- $V_- = R_1 \cdot I$
- $V_{out} = (R_1 + R_2) \cdot I$
- $\frac{V_{out}}{V_{in}} = \frac{I \cdot (R_1 + R_2)}{I \cdot R_1}$
- $V_{out} = \left(1 + \frac{R_2}{R_1}\right) \cdot V_{in}$

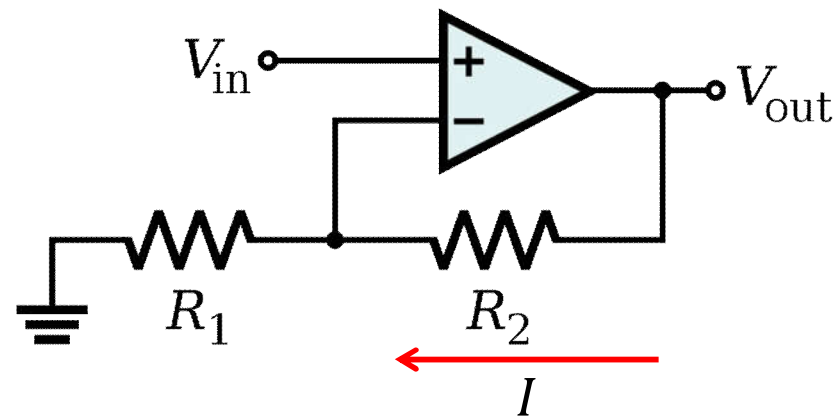

Non-inverting amplifier

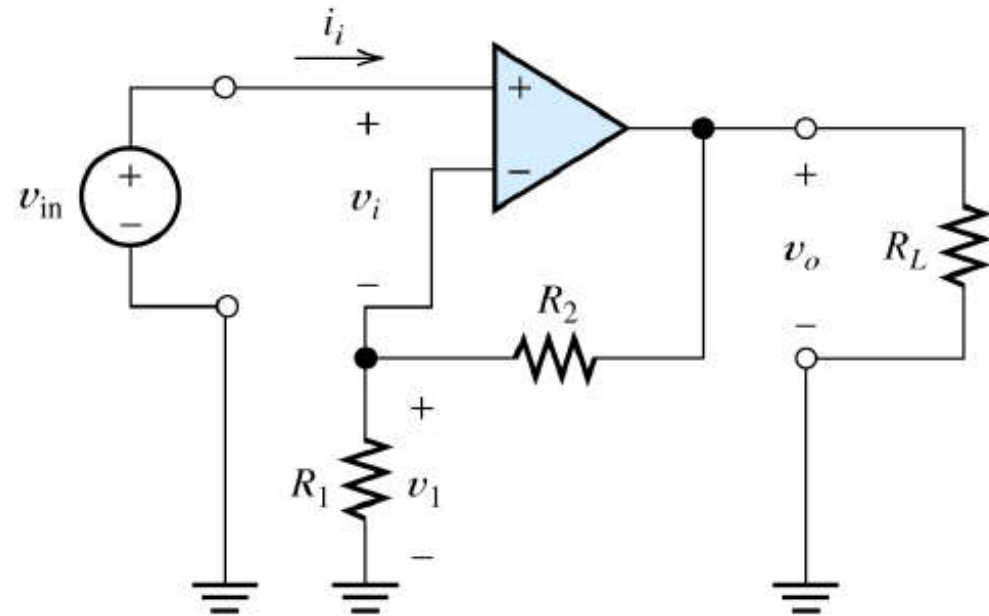

$$v_i = 0 \rightarrow v_1 = v_{in}$$

$$v_1 = \frac{R_1}{R_1 + R_2} v_o \rightarrow v_o = \frac{R_1 + R_2}{R_1} v_{in} = \left(1 + \frac{R_2}{R_1} \right) v_{in}$$

$$A_v = \frac{v_o}{v_{in}} = \left(1 + \frac{R_2}{R_1} \right)$$

Non-inverting Amplifier

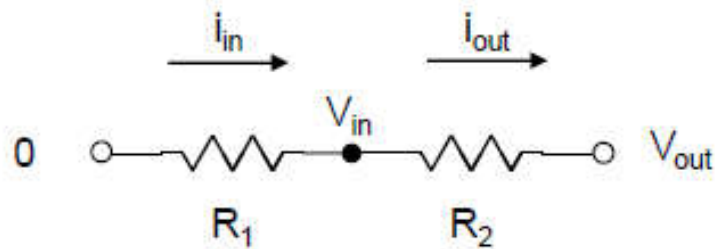

$$i_{in} = \frac{0 - v_{in}}{R_1}$$

$$i_{out} = \frac{v_{in} - v_{out}}{R_2}$$

$$i_{in} = i_{out} \rightarrow \frac{-v_{in}}{R_1} = \frac{v_{in} - v_{out}}{R_2}$$

$$\frac{v_{out}}{R_2} = \frac{v_{in}}{R_1} + \frac{v_{in}}{R_2}$$

$$v_{out} = v_{in} \left(1 + \frac{R_2}{R_1} \right)$$

Voltage follower

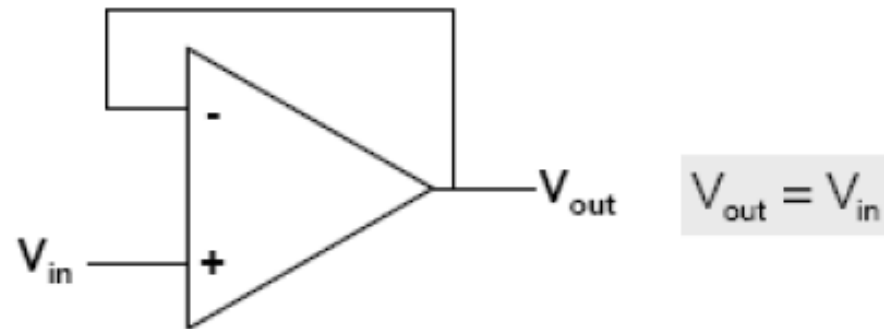

Voltage comparator

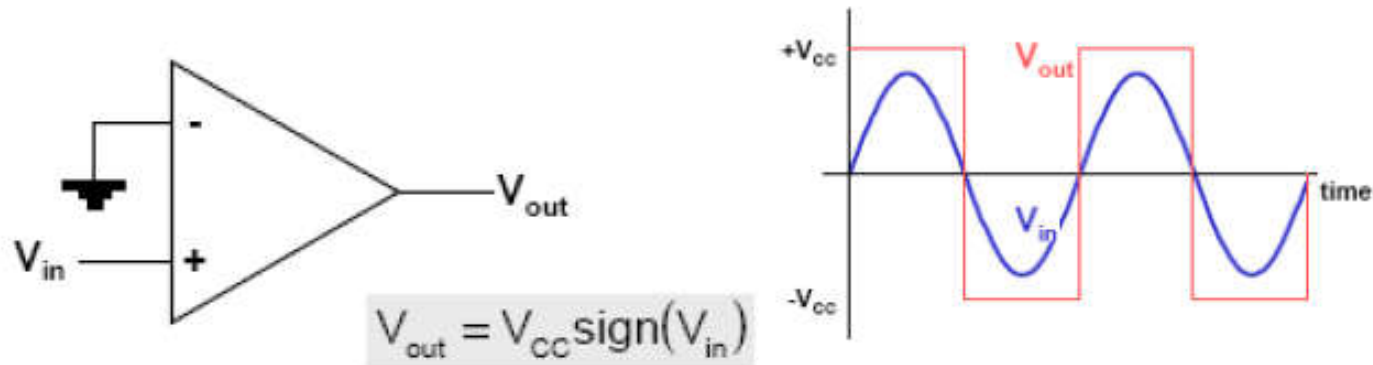

Voltage comparator

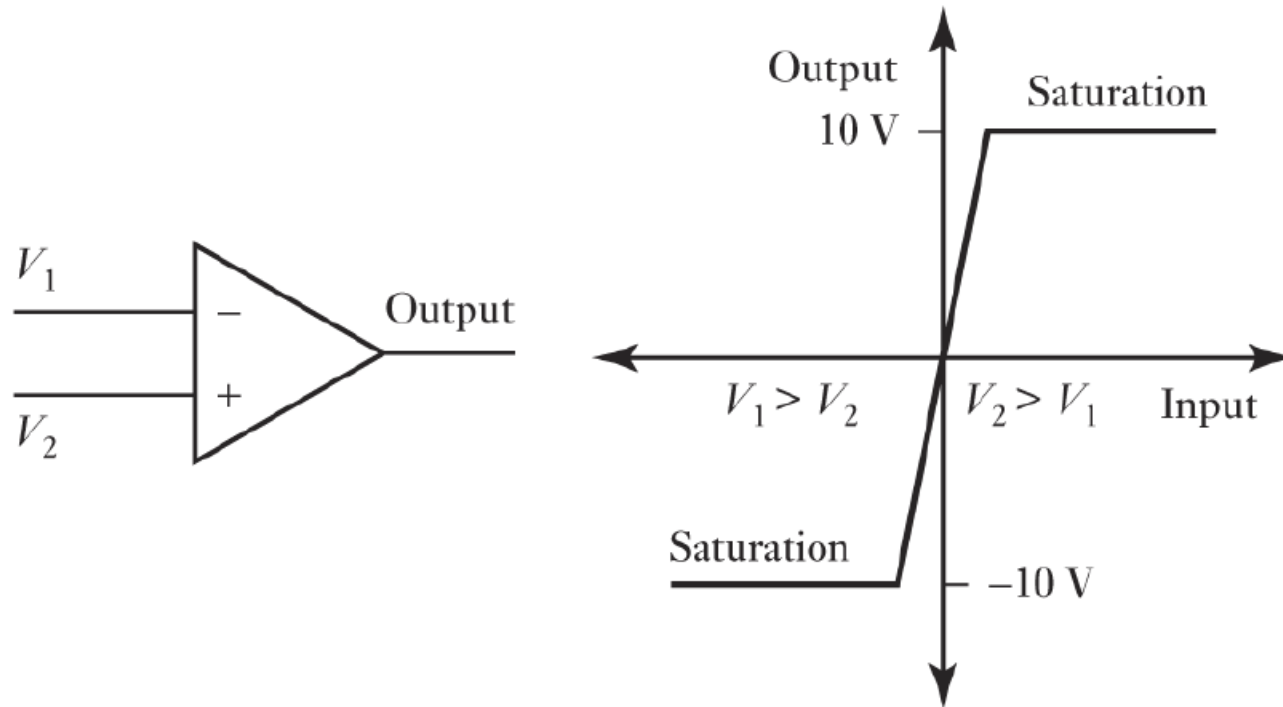

- For instance: If the voltage V_1 is greater than V_2 then the output is constant voltage equal to (-10V)
- If ($V_2 > V_1$) then the output is constant voltage =(+10V).

Voltage comparator

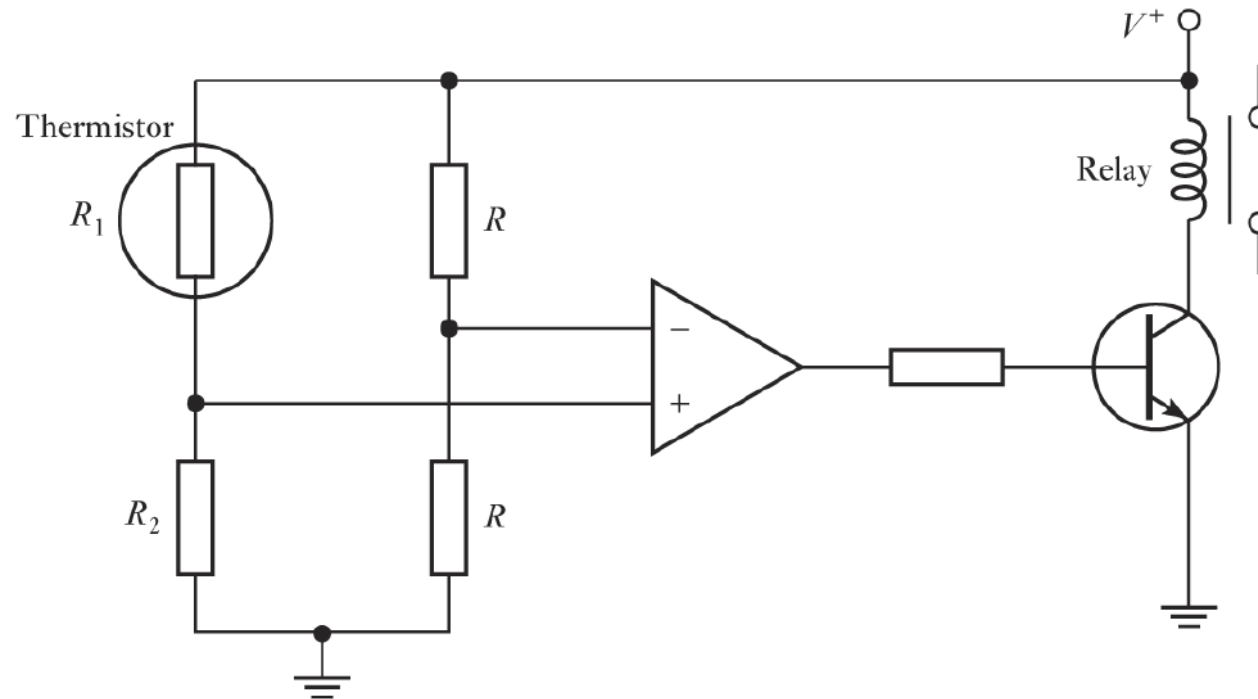

The circuit used to control temperature within a certain range. When the temp. is below reference value, the thermistor R_1 is more than R_2 and the bridge is out of balance. Thus, an output is at its lower saturation limit which keeps the transistor OFF. When temperature increases and R_1 falls the op-amp switch to +ve saturation value and switch the transistor ON.

Summing Amplifier

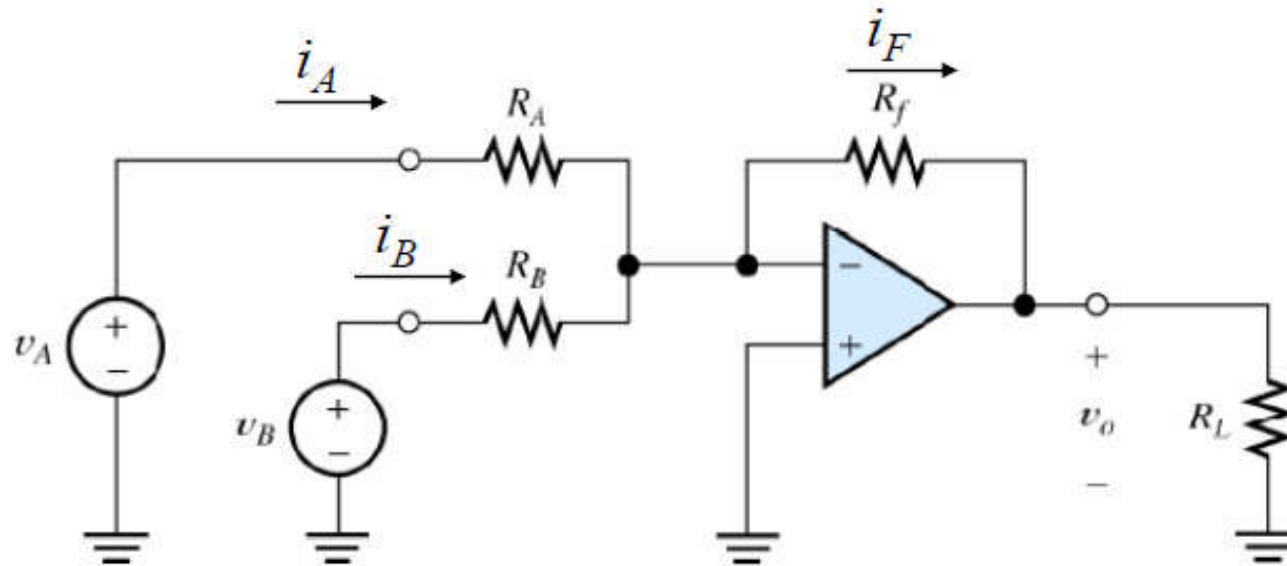

$$i_A = \frac{V_A}{R_A} \quad i_B = \frac{V_B}{R_B} \quad i_F = i_A + i_B = \frac{V_A}{R_A} + \frac{V_B}{R_B}$$

$$i_F = \frac{0 - v_o}{R_F} = \frac{-v_o}{R_F} = \frac{V_A}{R_A} + \frac{V_B}{R_B} \quad \rightarrow \quad v_o = -R_F \left(\frac{V_A}{R_A} + \frac{V_B}{R_B} \right)$$

Summing amplifier

- **Functionality:** takes the sum of two or more input voltages and provides an output voltage proportional to the negative of the algebraic sum

$$V_{out} = -R_f \left(\frac{V_1}{R_1} + \frac{V_2}{R_2} + \dots + \frac{V_n}{R_n} \right)$$

- If $R_1 = R_2 = \dots = R_n$:

$$V_{out} = -\frac{R_f}{R_1} (V_1 + V_2 + \dots + V_n)$$

- Moreover, if $R_f = R_1 = R_2 = \dots = R_n$:

$$V_{out} = -(V_1 + V_2 + \dots + V_n)$$

- By setting $\frac{R_f}{R_1} = \frac{1}{n}$, the summing op-amp can be used as an averaging operator:

$$V_{out} = -\frac{1}{n} (V_1 + V_2 + \dots + V_n)$$

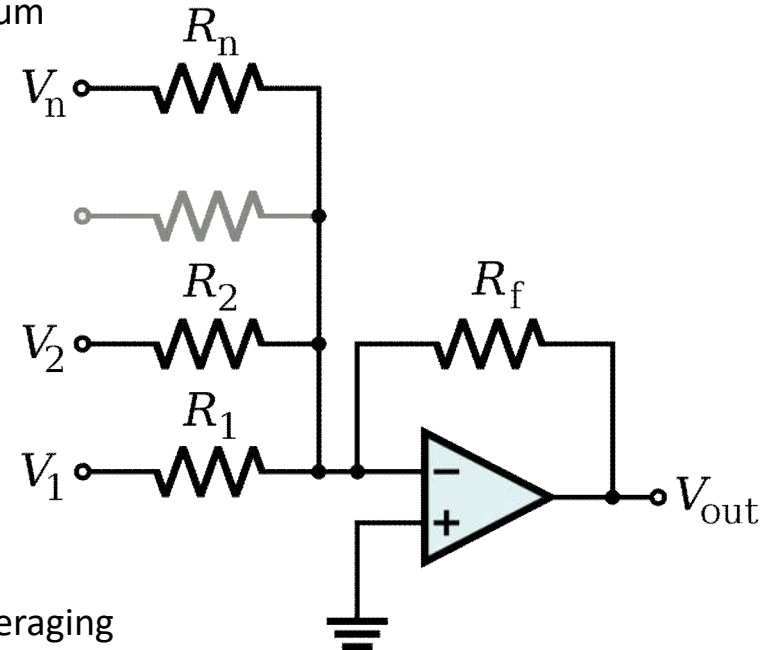

Differential amplifiers

- Functionality: takes the difference between two signals and provides that as the output

$$V_{out} = \left(\frac{R_1+R_f}{R_1}\right) \left(\frac{R_g}{R_g+R_2}\right) V_2 - \frac{R_f}{R_1} V_1$$

- If $\frac{R_f}{R_1} = \frac{R_g}{R_2}$:

$$V_{out} = \frac{R_f}{R_1} (V_2 - V_1)$$

- Moreover, if $R_f = R_1$:

$$V_{out} = V_2 - V_1$$

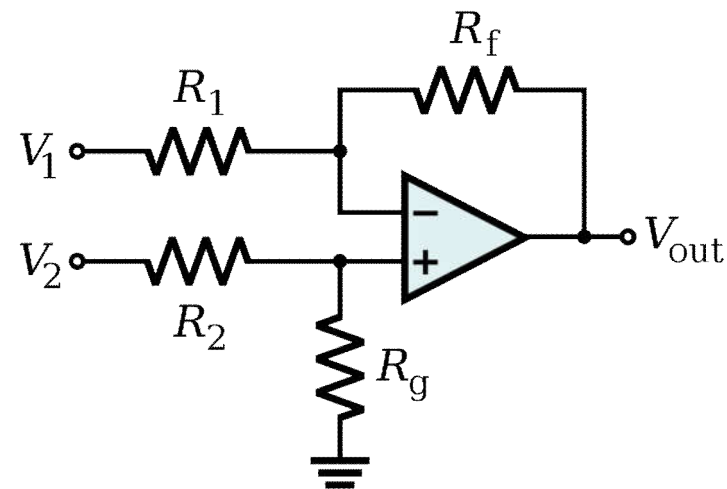

Differentiating and integrating elements

- There are certain applications → transducer output needs to be differentiated or integrated.
- E.g.: an electrodynamic transducer, the **output voltage** is proportional to the **velocity** of moving object.
- In case it is desired to measure the displacement and have an output proportional to it, it would be necessary to integrate the transducer output using an integrating element.
- Similarly, if the output is desired to be proportional to acceleration in the above case, a differentiating element is needed.

Integrating Amp

- Functionality: takes the summation of input voltages over time and provides that as the output signal

- $V_+ = 0\text{ V}$
- $V_-(t) = R \cdot I(t) = V_{in}(t)$
- $I(t) = \frac{V_{in}(t)}{R}$
- $V_{out} = -\frac{1}{C} \cdot \int_0^t I(\tau) d\tau$
- $V_{out} = -\frac{1}{RC} \cdot \int_0^t V_{in}(\tau) d\tau$

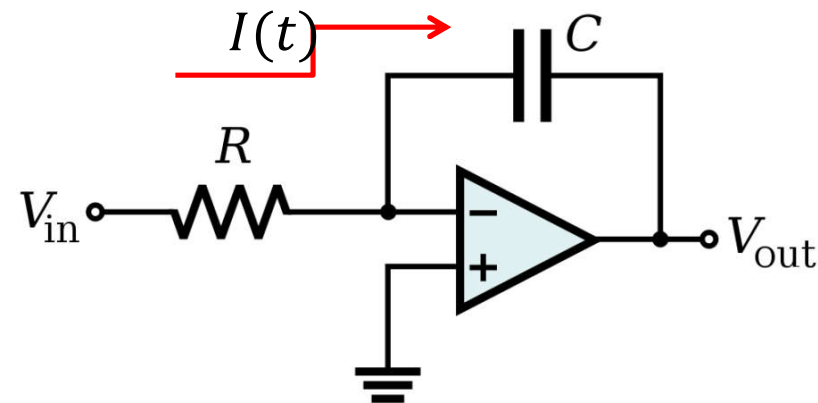

Differentiating/Derivative amplifier

- Functionality: takes the rate of change of the inverted input voltage signal and provides that as the output signal
- $V_+ = 0 V$
- $V_-(t) = V_{in}(t) = \frac{1}{C} \cdot \int I(t) dt$
- $I(t) = C \cdot \frac{dV_{in}(t)}{dt}$
- $V_{out} = -R \cdot I(t)$
- $V_{out} = -RC \cdot \frac{dV_{in}(t)}{dt}$

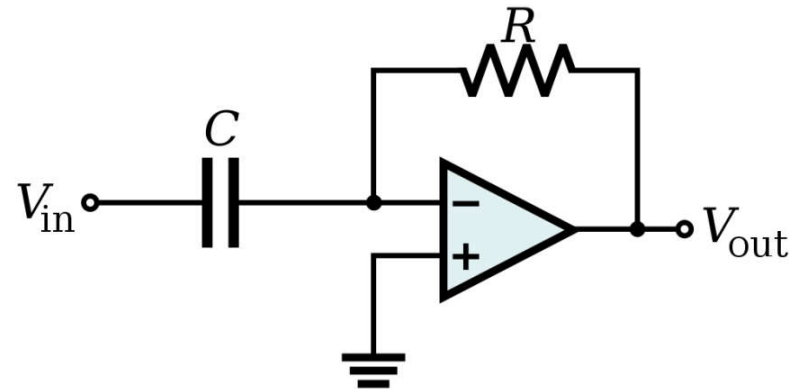

Applications

Low-Pass Filter

- Attenuate frequencies above the cutoff frequency.
- Cutoff frequency (Hz):

$$- f_c = \frac{1}{2\pi R_2 C}$$

- Gain in the passband:

$$- G = -\frac{R_2}{R_1}$$

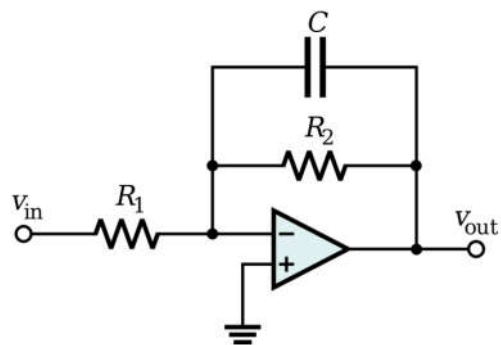

High-Pass Filter

- Attenuates frequencies below the cutoff frequency.
- Cutoff frequency (Hz):

$$- f_c = \frac{1}{2\pi R_1 C}$$

- Gain in the passband:

$$- G = -\frac{R_2}{R_1}$$

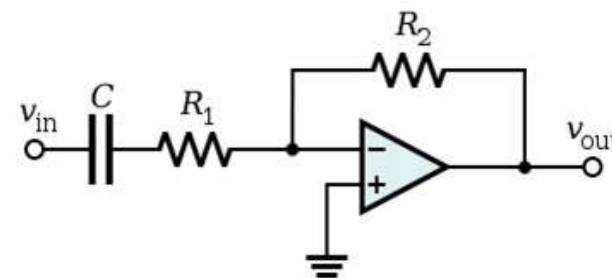

Applications

Bandpass Filter

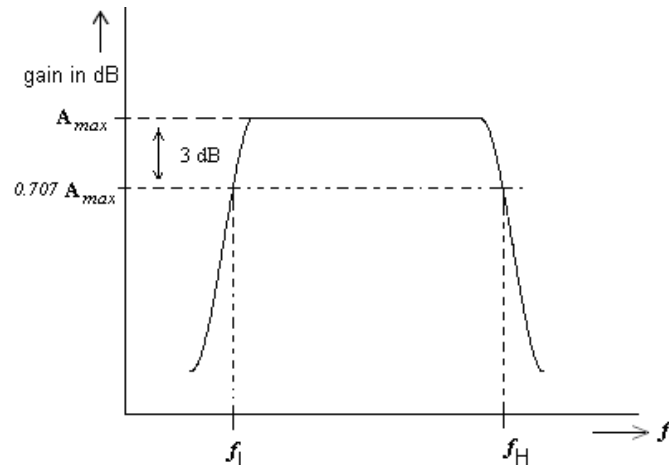
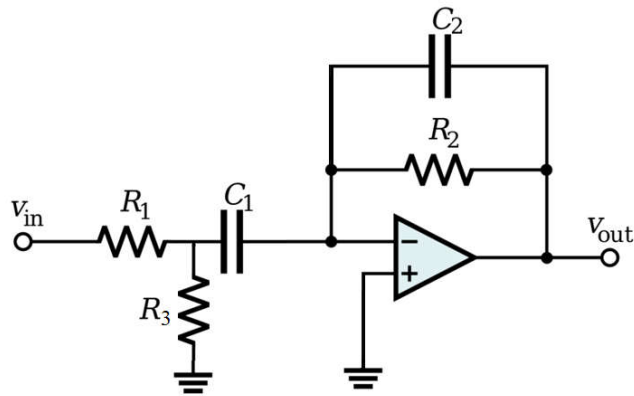

Notch Filter

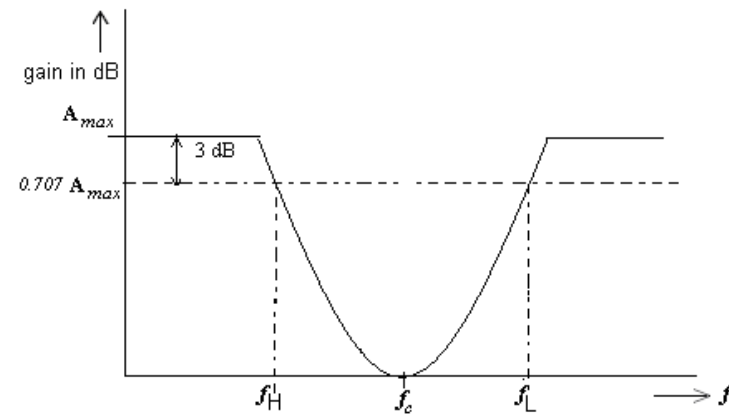
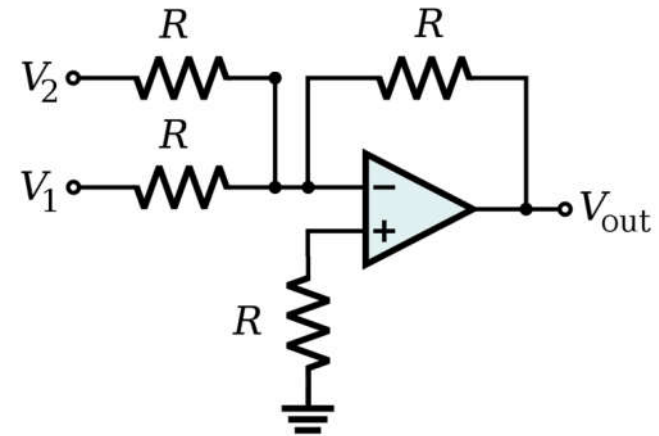



Design of Simple Amplifiers

Amplifier design using op amps mainly consists of selecting a suitable circuit configuration and values for the feedback resistors.

If the resistances are too small, an impractical amount of current and power will be needed to operate the amplifier.

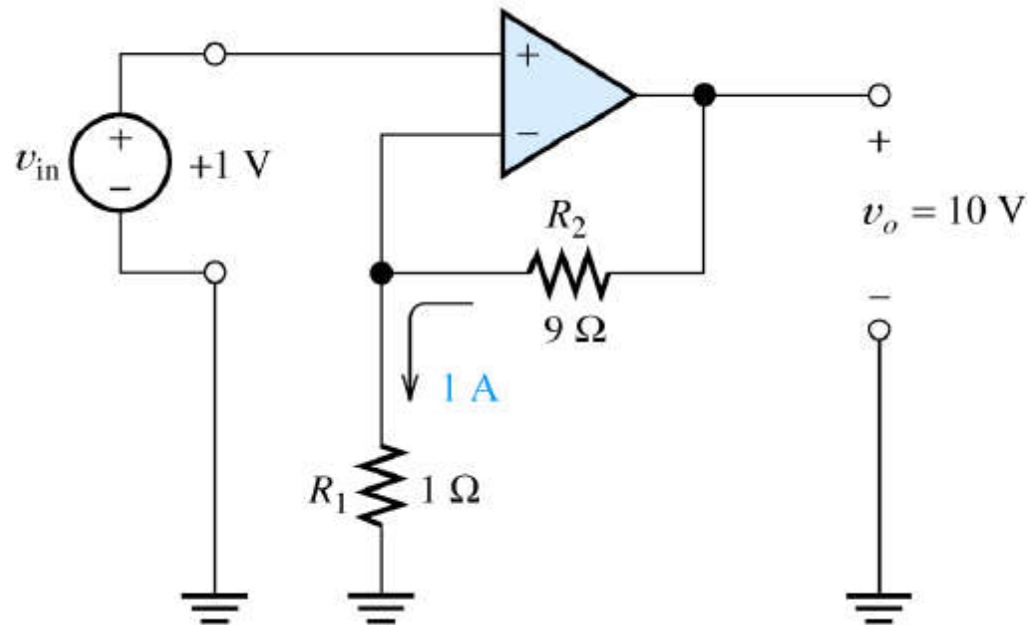

Very large resistance may be unstable in value and lead to stray coupling of undesired signals.

